

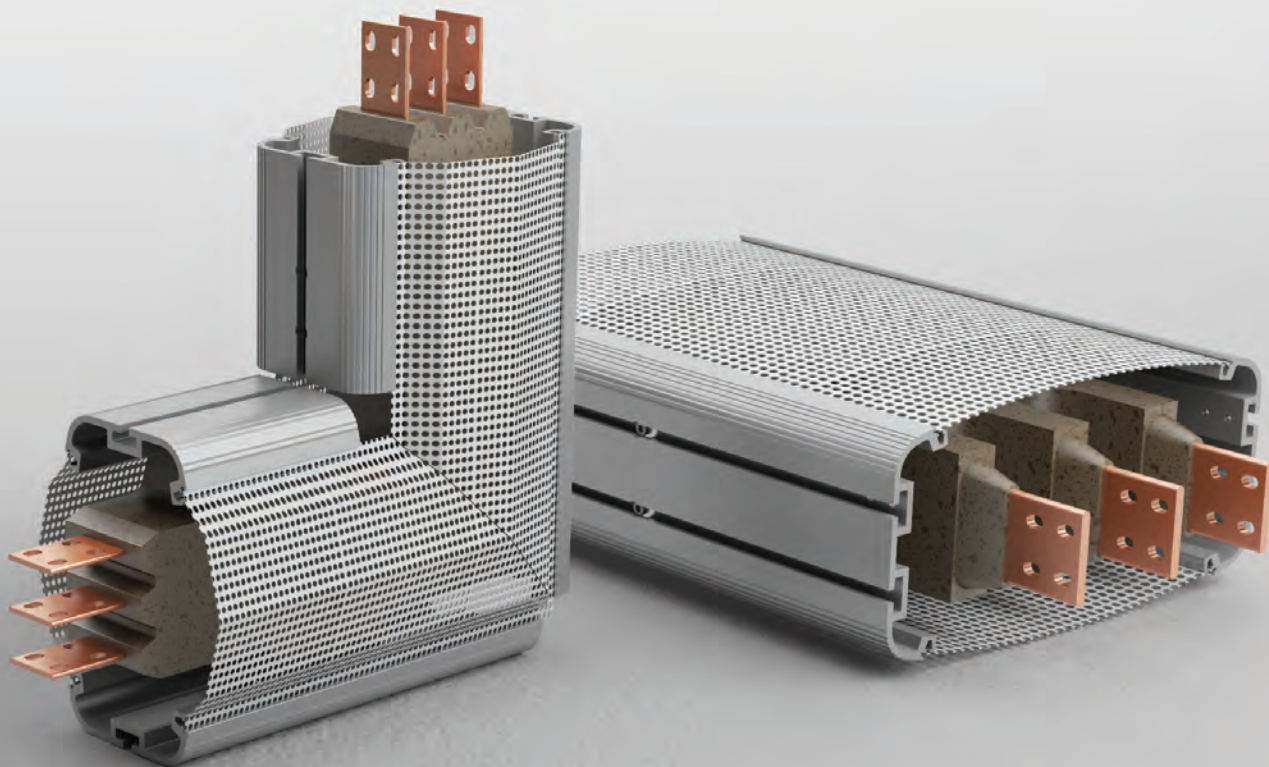

E-LINE MV

Medium Voltage Busbar Systems



E-LINE MV

Please visit our website for the updated version of our catalogues.
www.eaelectric.com



CONTENTS

►► E-LINE MV

General Introduction.....	2-3
12kV	
Order Code System	4
Technical Characteristics.....	5
Standard Straight Length.....	6
Elbows.....	7
Horizontal & Vertical Cast Resin Busbar Applications.....	8
Trunking Support / 12 kV Additional Zone Weights.....	9-10
Panel Connection.....	11
Horizontal Application.....	12
Vertical Application.....	13
General Product Specifications.....	14
Certificate.....	15
17,5kV	
Order Code System	16
Technical Characteristics.....	17
Standard Straight Length.....	18
Elbows.....	19
Horizontal & Vertical Cast Resin Busbar Applications.....	20
Trunking Support / 12 kV Additional Zone Weights.....	21-22
Panel Connection.....	23
Horizontal Application.....	24
Vertical Application.....	25
General Product Specifications.....	26
Certificate.....	27

E-LINE MV

General Introduction



Petrochemical Industry

Oil&Gas Industry

Power Generation Industry



Medium Voltage (MV) is manufactured within a single housing, the conductor copper are embedded in DURACOMP insulation which is a composite material of epoxy resin and pure silica minerals with Cu conductors specially selected and the epoxy resin. Medium Voltage busbar systems are designed to operate at voltages of 12kV and 17,5kV. Manufactured as standard up to a rating of 5000 A. Please contact us for higher amperage applications.

Areas of Use

Exterior environments, industrial buildings, petrochemical buildings, regions with flood risk, oil and natural gas industry

MV System Benefits

- ▶ Products tested in accordance with international standards
- ▶ Corrosion-resistant
- ▶ Chemical-resistant
- ▶ Resistance against insects and rodents
- ▶ Usable in tropical environments
- ▶ High mechanical strength
- ▶ Without stack effect
- ▶ Highly resistant to short circuit
- ▶ Low voltage drop when compared with cable
- ▶ Special design for occupying minimum space based on ampere level.
- ▶ Electroerosion resistant
- ▶ UV resistant
- ▶ Designed to improve heat loss
- ▶ Maintenance-free busbar
- ▶ Easy Assembly
- ▶ An ideal high temperature environments

Short-Circuit Withstand

Short-circuit resistance values tested are presented on the table. High busbar resistance can be seen based on the short-circuit values to be calculated.

Busbar Drawings

You may receive professional assistance is available to our clients by contacting our nearest dealer, distributor or our Project & Design departments for Busbar drawings Blueprints and calculating cost estimates.

* Modules required for special situations can be manufactured in a short time.

E-LINE MV

General Introduction



High IP Insulation

DURACOMP is a composite material of epoxy resin and pure silicon which gives the E-LINE MV busbar range a high mechanical strength and resistance to high temperatures and external effects as listed on Page 2

EAE Medium voltage busbar systems are manufactured using high density and high conductivity copper conductors. Contact areas of copper conductors can be coated by tin or optionally silver.

Ease of Heat Transfer

Heat forming on the additives used in the system with high heat transfer is easily dissipated to the environment by means of the housing.

Short-Circuit Withstand

High mechanical and thermal resistance thanks to the DURACOMP material.

Housing:

E-Line MV busbar is produced by combining the Duracomp insulated conductor within an extruded aluminium housing.

- Light aluminium case
- High Mechanical Strength and Chemical Resistance
- Adjustable support system
- Safety earth continuity
- Very less magnetic field

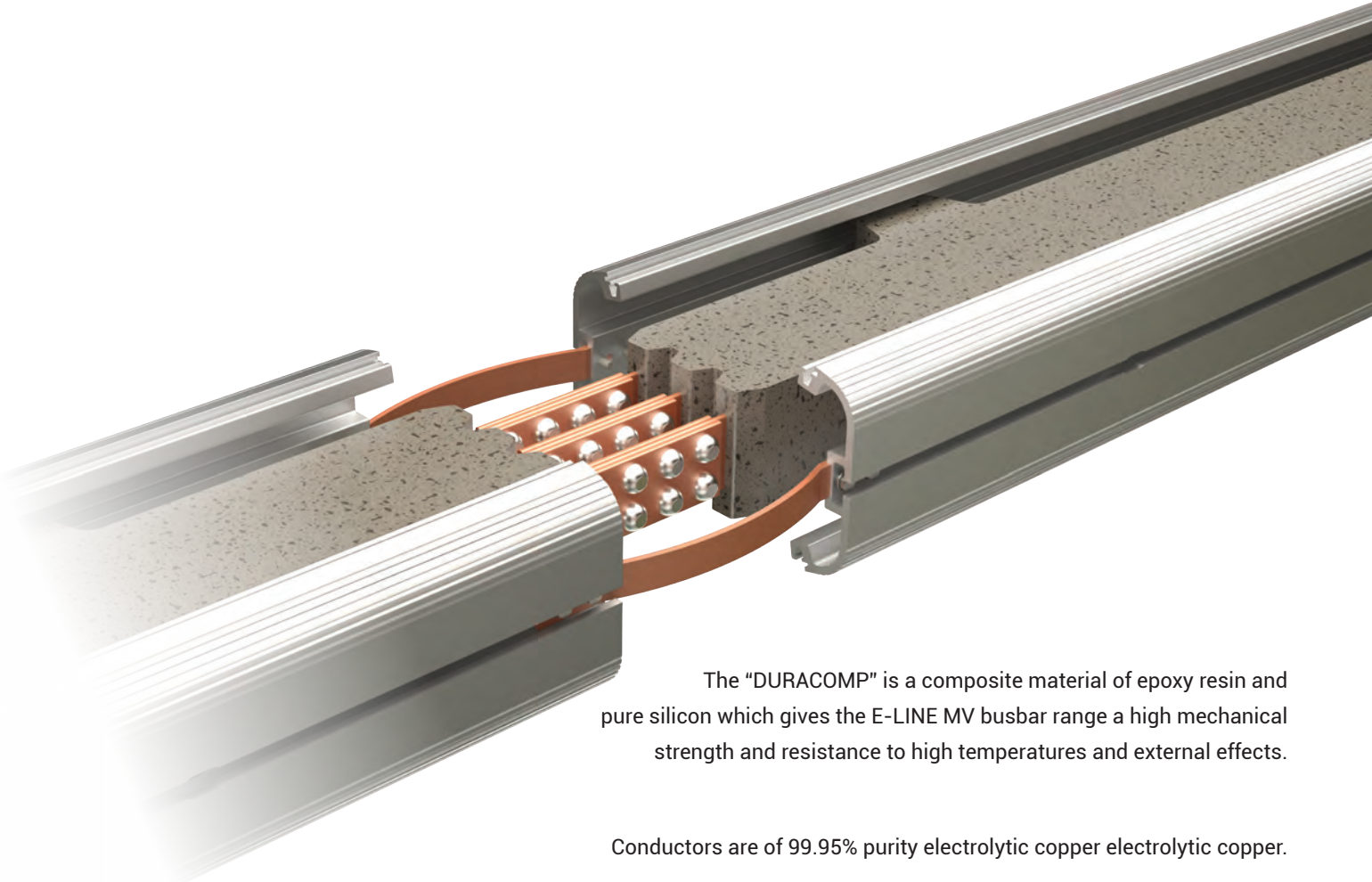

The "DURACOMP" is a composite material of epoxy resin and pure silicon which gives the E-LINE MV busbar range a high mechanical strength and resistance to high temperatures and external effects.

Conductors are of 99.95% purity electrolytic copper electrolytic copper.

E-LINE MV

Order Code System

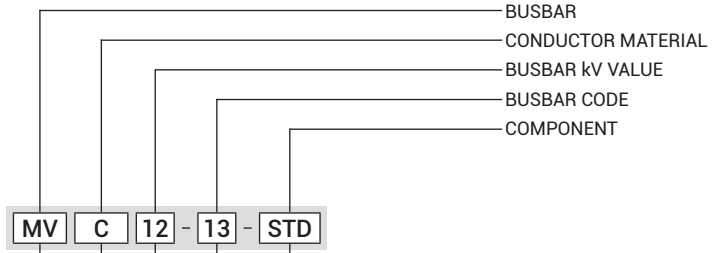

Busbar Type

Copper (Cu) C

CONDUCTOR MATERIAL

BUSBAR kV VALUE	Code	Conductor Configuration		
		L1	L2	L3
12kV	12	✓	✓	✓

BUSBAR kV VALUE

(* Please call us for different kV values.

MVC - Cu Conductor		Conductor Cross Section
Rated Current	Busbar Code	
950	09	6x40
1150	11	6x55
1350	13	6x70
1650	16	6x95
2250	22	6x140
2750	27	6x200

BUSBAR CODE

- Standard Straight Length.....STD
- Special Straight Length.....X

- Upwards Elbow.....U
- Downwards Elbow.....D
- Left Elbow.....L
- Right Elbow.....R
- Panel Connection.....P10

Component

► Copper Conductor (Cu)

Rated Current	I_r	A	950	1150	1350	1650	2250	2750
Busbar Code			09	11	13	16	22	27
Standards	IEC 62271-200 Edition 2.0 2011-10; IEC 62271-307 Edition 1.0 2015-09;			IEC 61439-6 Edition 1.0 2012-05; STL Guide to IEC 62271-200				
Rated Voltage	U_r	kV	12	12	12	12	12	12
Rated power frequency withstand voltage	U_d	kV	28	28	28	38	38	38
Rated impulse withstand voltage	U_p	kV	75	75	75	95	95	95
Rated Frequency	f_r	Hz	50	50	50	50	50	50
Partial Discharge		pC	< 20	< 20	< 20	< 20	< 20	< 20
External Mechanical Impacts (IK Code)*	50J, greater than IK10							
Rated Short-time Withstand Current (1s)	I_k	kA_{rms}	25	25	43	43	71,3	71,3
Rated Peak Withstand Current	I_{ke}	kA	65	65	112	112	185,5	185,5
Rated Short-time Withstand Current for PE Conductor (1s)	I_p	kA	15	15	26,3	26,3	42,4	42,4
Rated Peak Withstand Current for PE Conductor	I_{pe}	kA	39	39	72,4	72,4	110,2	110,2
MEAN PHASE CONDUCTOR CHARACTERISTICS AT RATED CURRENT I_n								
Resistance at a conductor temperature of 20°C	R_{20}	mΩ/m	0,077	0,057	0,045	0,0352	0,0223	0,0162
Resistance at an ambient air temperature of 35°C	R	mΩ/m	0,104	0,078	0,061	0,0474	0,0304	0,0224
Reactance (Independent from Temperature)	X	mΩ/m	0,116	0,097	0,084	0,0788	0,0576	0,0442
Positive and negative sequence impedances at an ambient air temperature of 35°C	Z	mΩ/m	0,156	0,125	0,104	0,0919	0,0651	0,0496
Positive and negative sequence impedances at an ambient air temperature of 20°C	Z_{20}	mΩ/m	0,139	0,113	0,096	0,0863	0,0618	0,0471
Rated Power Loss at 35°C		Watt	278	297,1	324	370,3	443,3	491,7
DC Resistance at a conductor temperature of 20 °C for Phases	R_{phdc}	mΩ/m	0,071	0,050	0,039	0,030	0,019	0,013
DC Resistance at a conductor temperature of 20°C for PE	R_{PEdc}	mΩ/m	0,012	0,012	0,012	0,009	0,006	0,013
SECTIONS								
Phase Conductor		mm ²	240	330	420	570	840	1200
PE (Housing)		mm ²	5944	5944	5944	8105	8905	9704
Conductor Cross Section		mm x mm	6x40	6x55	6x70	6x95	6x140	6x200
Busbar Weight (3 Conductors)		kg/m	48,32	56,85	63,89	76,18	97,13	124,54
MEAN FAULT-LOOP CHARACTERISTICS								
Zero-sequence Impedance								
Zero-sequence impedance at a conductor temperature of 20°C	$Z_{(0)b20phPE}$	mΩ/m	0,309	0,292	0,271	0,248	0,203	0,176
Zero-sequence impedance at an ambient temperature of 35°C	$Z_{(0)bphPE}$	mΩ/m	0,328	0,307	0,285	0,258	0,210	0,182
Mean Resistances and Reactances								
Resistance at a conductor temperature of 20°C	$R_{b20phph}$	mΩ/m	0,150	0,112	0,088	0,073	0,049	0,035
Resistance at a conductor temperature of 20°C	$R_{b20phPE}$	mΩ/m	0,089	0,071	0,059	0,049	0,035	0,028
Resistance at an ambient air temperature of 35°C	R_{bphph}	mΩ/m	0,203	0,153	0,121	0,099	0,067	0,048
Resistance at an ambient air temperature of 35°C	R_{bphPE}	mΩ/m	0,120	0,096	0,081	0,065	0,048	0,038
Reactance (Independent from temperature)	X_{bphph}	mΩ/m	0,221	0,184	0,160	0,150	0,115	0,084
Reactance (Independent from temperature)	X_{bphPE}	mΩ/m	0,170	0,153	0,140	0,129	0,106	0,087

Standards

⁽¹⁾The weight per metre provided in table includes 1/3 of the weight of one block joint.

E-LINE MV

Standard Straight Length

► Standard Feeder Straight Length

STD

Sample Order:

MVC 1213 - STD
12 kV 1350 A, Copper,
Feeder, 3 Conductors

L1 L2 L3

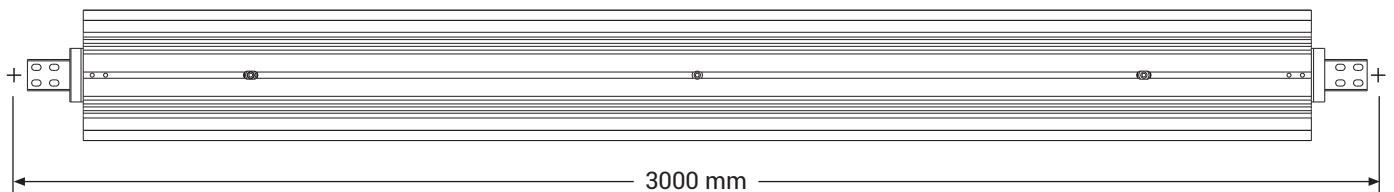
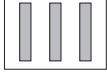

► Special Feeder Straight Length

X

Sample Order:

MVC 1209 - X - 150
12 kV 950 A, Copper, Feeder,
3 Conductors, 1500 mm Special Length

L1 L2 L3



Information:
Feeder Minimum
Special length size = 1000 mm

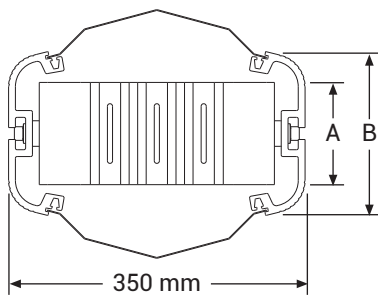
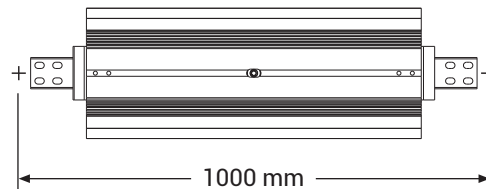

► Table of Busbar Cross Section Sizes

MVC - Cu Conductor	Rated Current (A)	950	1150	1350	1650	2250	2750
	Busbar Code	09	11	13	16	22	27
A	mm	90	105	120	145	190	250
B	mm	192	192	192	247	297	347



Attention ! The standard mounting of the MV busbar is with the conductors on edge. This allows for the easy application of the resin at the joint.

E-LINE MV

Elbows



► Upwards Downwards Elbow

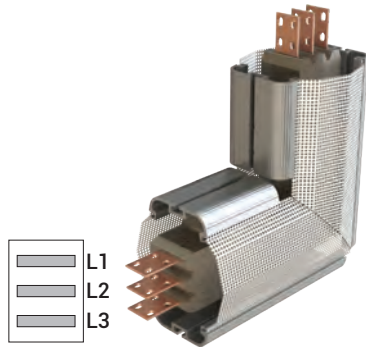

U
D

Sample Order:

MVC 1211 - U
12 kV 1150 A, Copper, Feeder,
3 Conductors

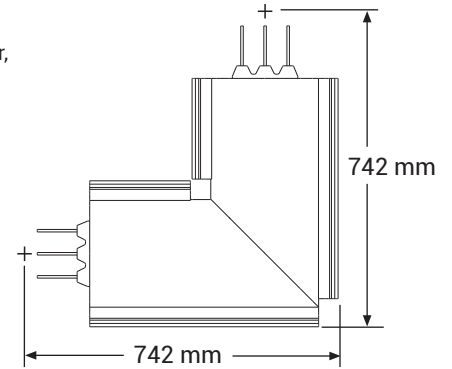

► Left Right Elbow

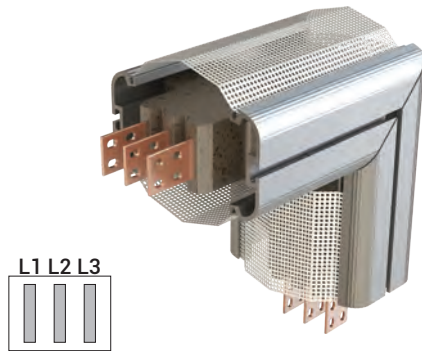

R
L

Sample Order:

MVC 1209 - R
12 kV 950 A, Copper, Feeder,
3 Conductors

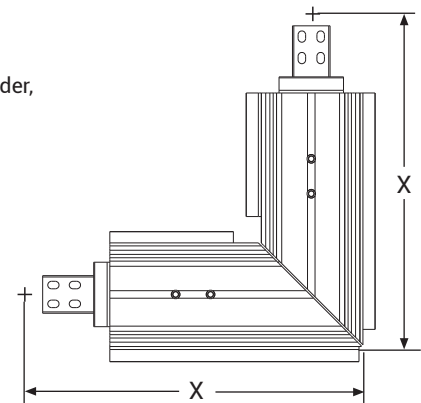

► Table of Busbar Cross Section Sizes

MVC - Cu Conductor	Rated Current (A)	950	1150	1350	1650	2250	2750
	Busbar Code	09	11	13	16	22	27
X	mm	580	590	595	635	685	740

► Panel Connection

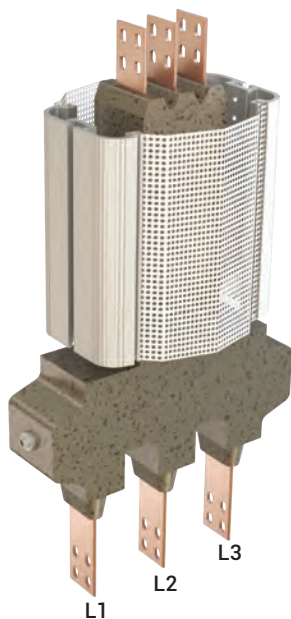

P10
T10

Sample Order:

MVC 1213 - P10
12 kV 1350 A, Copper,
Feeder, 3 Conductors
For Panel Feeder

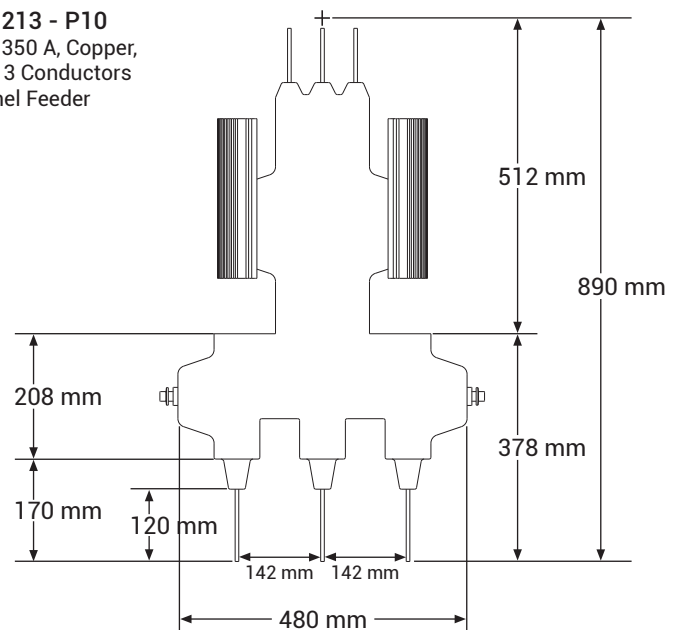

12 kV

E-LINE MV

Horizontal & Vertical Cast Resin Busbar Applications



FIGURE 1 - EDGEWISE APPLICATION

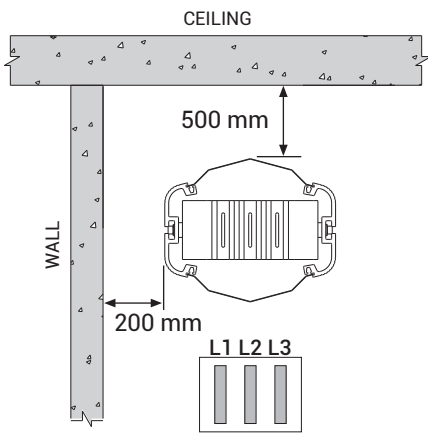
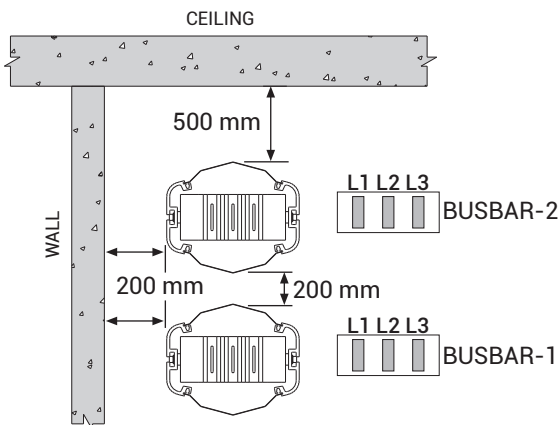

FIGURE 2 - EDGEWISE APPLICATION



Primarily on the installation phase;
BUSBAR-1 line should be installed before BUSBAR-2 line.

FIGURE 3 - CROSSING UNDER A BEAM ON EDGEWISE APPLICATION

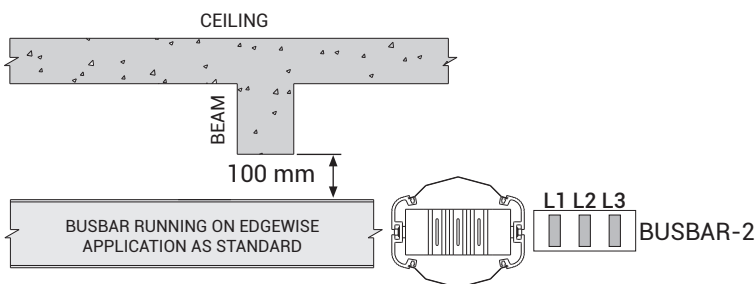

FIGURE 4 - SAMPLE WALL CROSSING WITH FIRE BARRIER

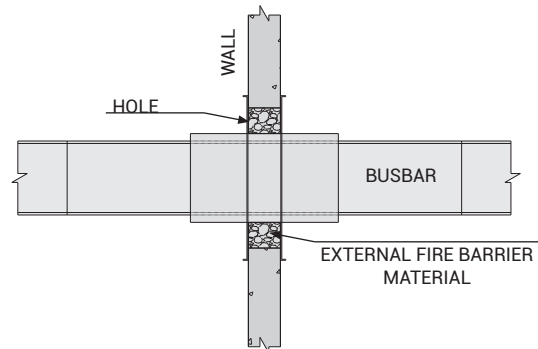
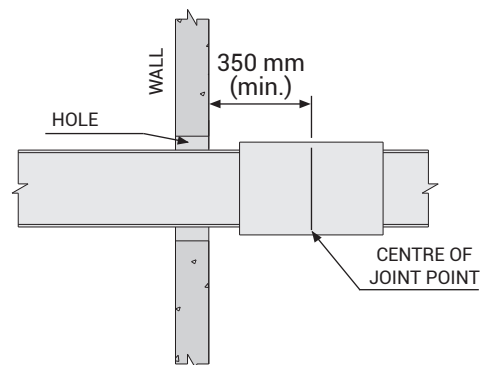

FIGURE 5 - STANDARD WALL CROSSING



⚠ Attention !

- For correct installation, the dimension from the busbar to the ceiling should not be less than 500mm
- The joint should be not come across to Beams.
- The dimensions given above are minimum values.
- All dimensions are given in mm.

► Cast Resin Installation Tools

Description	Order Code
CR Joint Area Mixer	5000132
CR Plastic Hammer	5000310
CR Spoon Brush	5000311
MV Allen Torque Set	5000664
Disposable Coverall	5003622



E-LINE MV

Trunking Support

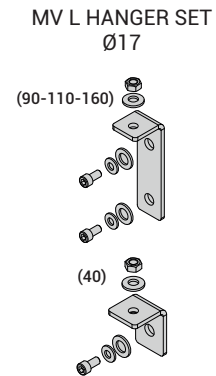
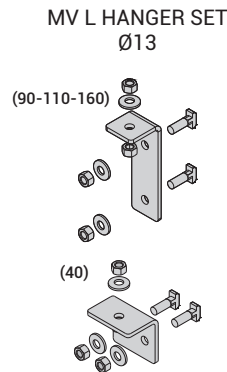
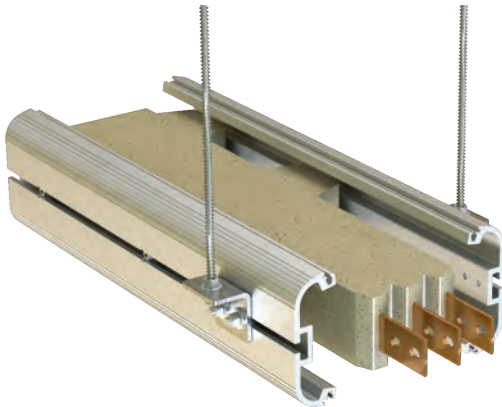

► MV "L" Hanger Set Code

MVC - Cu Conductor		Conductor Dimensions	MV "L" Hanger Set Code			
Rated Current	Busbar Code		Description	Order Code	Description	Order Code
950	09	6x40				
1150	11	6x55	MV L HANGER SET Ø13-(40)	3191532	MV L HANGER SET Ø17-(40)	3191533
1350	13	6x70				
1650	16	6x95	MV L HANGER SET Ø13-(90)	3180150	MV L HANGER SET Ø17-(90)	3180153
2250	22	6x140	MV L HANGER SET Ø13-(110)	3180151	MV L HANGER SET Ø17-(110)	3180154
2750	27	6x200	MV L HANGER SET Ø13-(160)	3180152	MV L HANGER SET Ø17-(160)	3180155

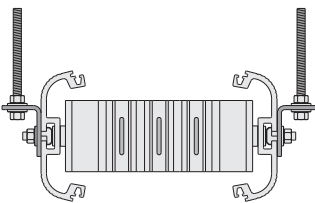

Note: Ø17 Panel Connection for Special Suspension.
It is not included in the rod hanger set.

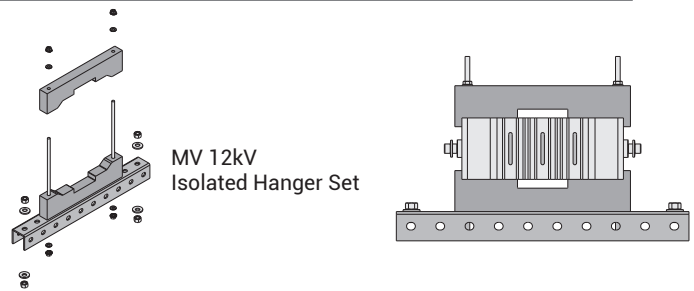
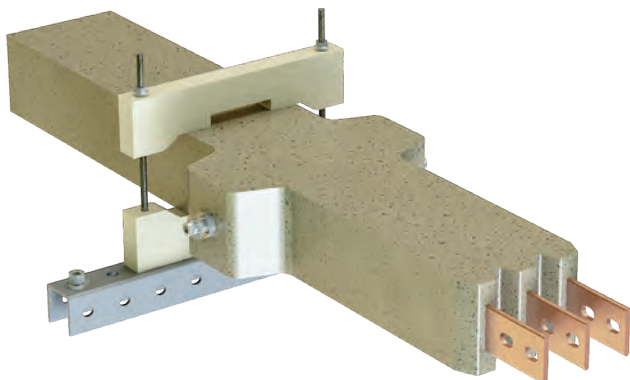

MV 12kV Isolated Hanger Set

► MV 12kV Isolated Hanger Set Code

MVC - Cu Conductor		Conductor Dimensions	MV 12kV Isolated Hanger Set Code	
Rated Current	Busbar Code		Description	Order Code
950	09	6x40		
1150	11	6x55	MV 12kV ISOLATED HANGER SET	3195616
1350	13	6x70		
1650	16	6x95		
2250	22	6x140	MV 12kV ISOLATED HANGER SET	3195562
2750	27	6x200		

► 12kV Additional Zone Weights

MVC - Cu Conductor		Conductor Dimensions	Weight (kg)
Rated Current	Busbar Code		
950	09	6x40	12,0
1150	11	6x55	13,5
1350	13	6x70	14,0
1650	16	6x95	15,5
2250	22	6x140	18,5
2750	27	6x200	22,5

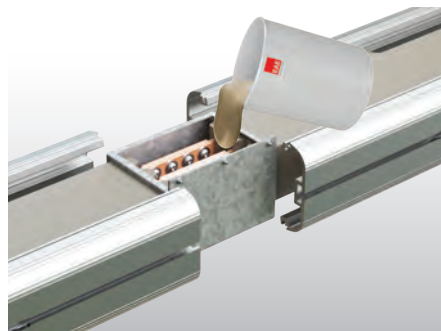

Total mixture weight of 1 Bucket is 15 kg

15 kg.

● When determining the material to be consumed for joint point, the installation of joint point weighing 15 kg and its multiples should be included in the work plan for the same day. Otherwise, since the remaining material will happen a curing reaction, it cannot be used in another day's work plan and will be scrapped. Material planning should be done taking this detail into consideration.

E-LINE MV

Trunking Support

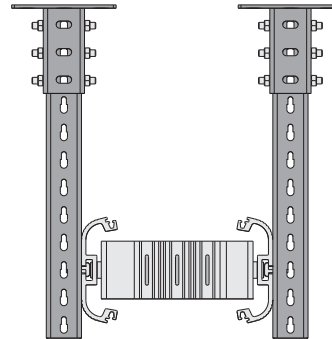
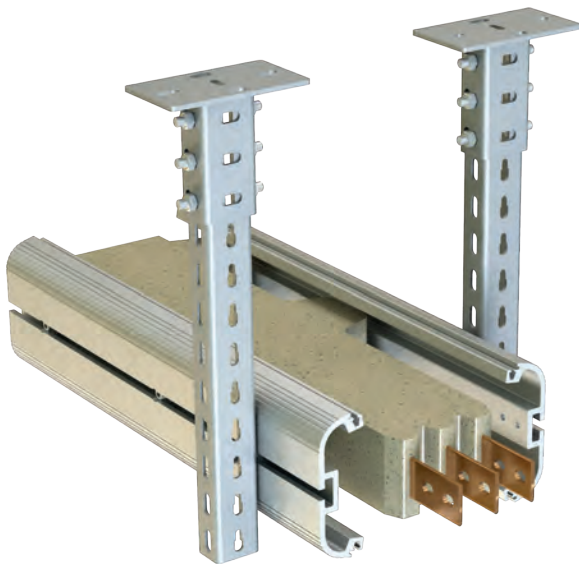

► Ceiling Fixing Element

Description	T (mm)	Tensile Load (kg.)	Weight (kg./pcs)	Order Code	Pack (pcs)
TMP 3	4	900	1,689	3086554	10

Note: The bolt set is not included in the product.
Please order separately.

TMP 3 Fixing Element Mounting;
6 pcs M10x30 Bolt,
12 pcs M10 Washers,
6 pcs M10 Spring Washers,
6 pcs M10 Nuts
should be used.

► Heavy Duty Supports (U)

Description	T (mm)	L (mm)	Weight (kg./pcs)	Order Code
UPY 150	4	150	0,586	3004486
UPY 300	4	300	1,172	3004487
UPY 400	4	400	1,562	3004489
UPY 500	4	500	1,956	3004491
UPY 600	4	600	2,343	3004493
UPY 700	4	700	2,728	3004495
UPY 800	4	800	3,124	3004496
UPY 900	4	900	3,515	3004497
UPY 1000	4	1000	3,945	3004498
UPY 1100	4	1100	4,296	3004499
UPY 1200	4	1200	4,686	3004500
UPY 1300	4	1300	5,071	3004501
UPY 1400	4	1400	5,467	3004502
UPY 1500	4	1500	5,917	3004503
UPY 1600	4	1600	6,248	3004504
UPY 1700	4	1700	6,633	3004505
UPY 1800	4	1800	7,029	3004506
UPY 1900	4	1900	7,414	3004507
UPY 2000	4	2000	7,811	3004508
UPY 3000	4	3000	11,716	3001954

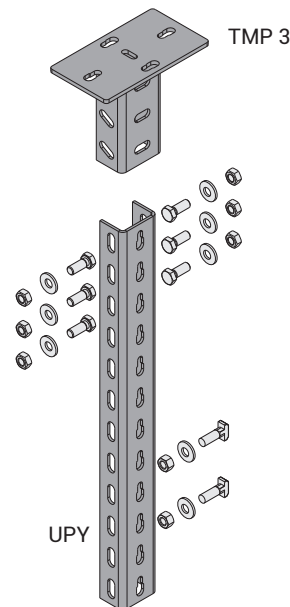

E-LINE MV

Panel Connection



► Two Dimensional Drawings of Panel Modules P10 Panel Mounted Modules

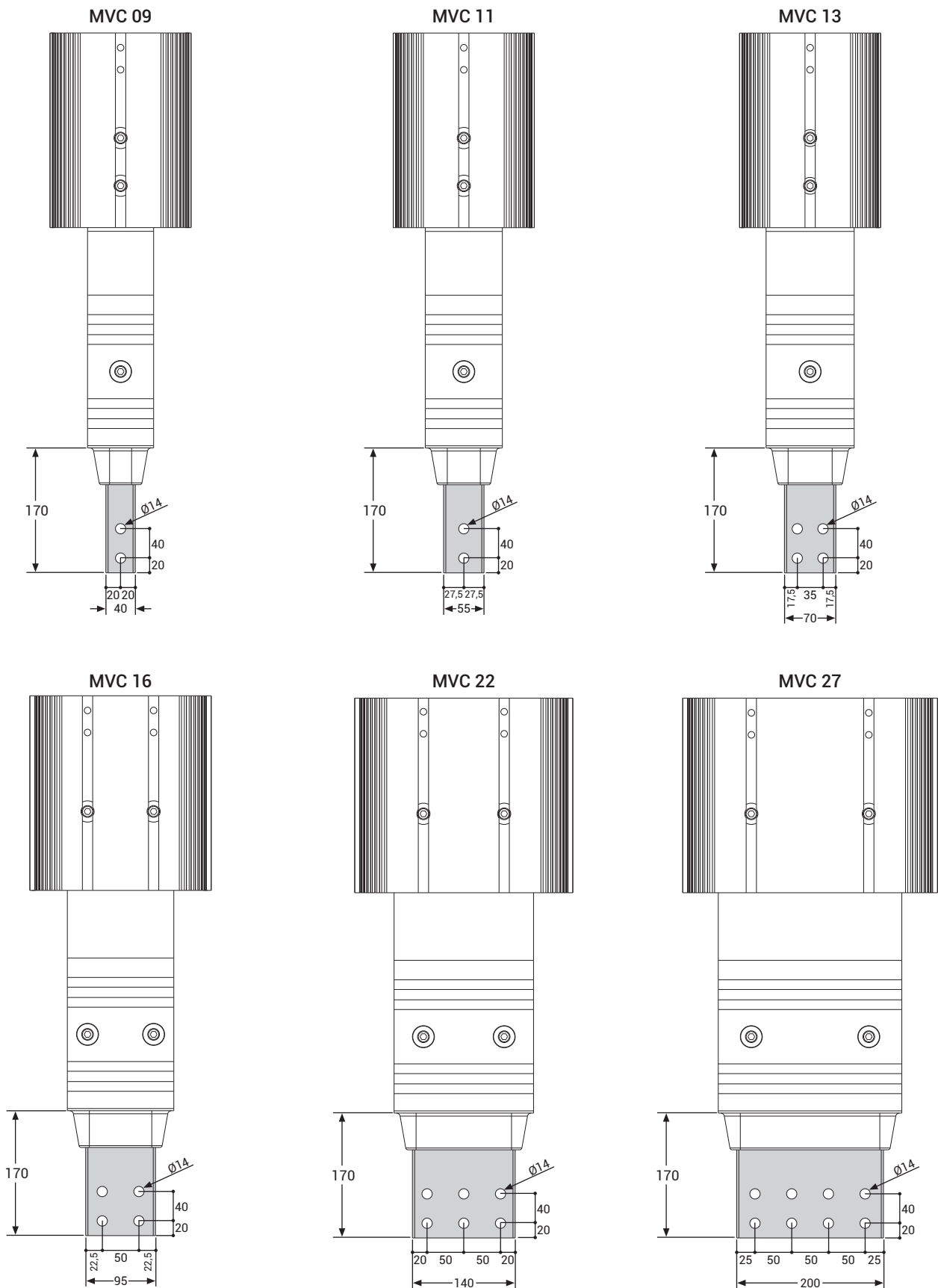

12 kV

E-LINE MV

Horizontal Application

1

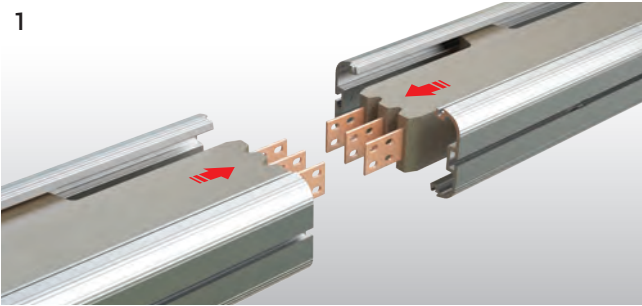

The ends of the conductors of the busbars are cleaned with a clean dry cloth. The busbars have to be fixed in the same axis, with a max. distance of 10 mm between the two conductors.

2

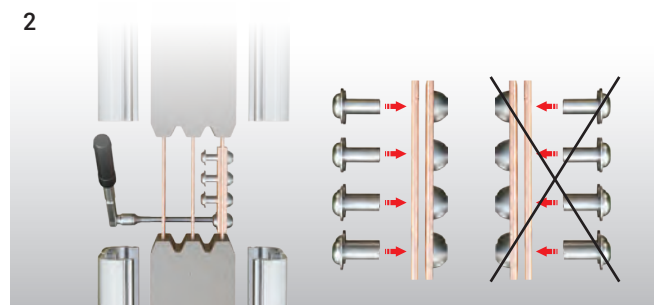

As shown on the figure, junction plates fixed as the bolts face the same direction at all times.

3

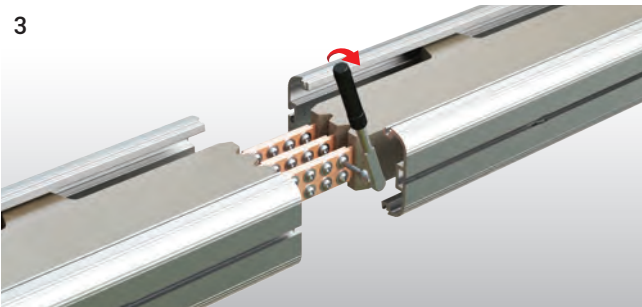

All bolts must be tightened to 72 Nm with torque wrench.

4

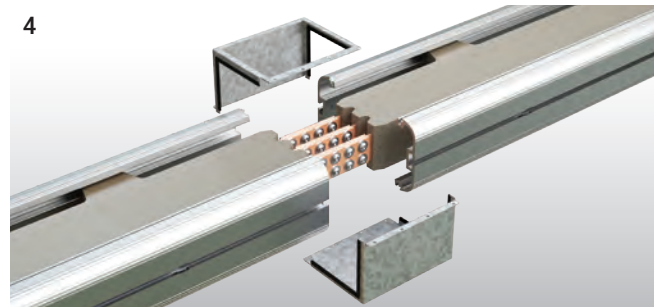

Before assembling the casting moulds, inner surfaces of casting moulds have to be wiped with clean dry cloth.

5

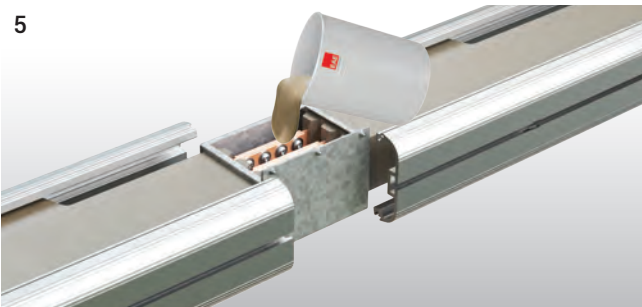

The prepared for casting should be cast from the same spot at all times.

6

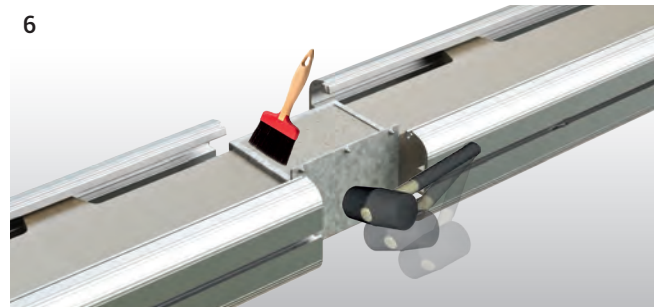

The material should be 'vibrated' with the help of a plastic hammer to remove the air in the material. Then the air bubbles on the surface have to be brushed.

7

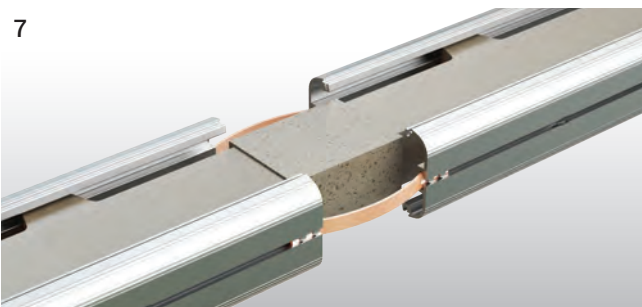

After the curing of the cast material is completed the sheet metal moulds can be removed. (Reaction is completed within 8 - 24 hours based on the air temperature.) The flexibles are fitted to the profiles grooves for earth continuity.

8

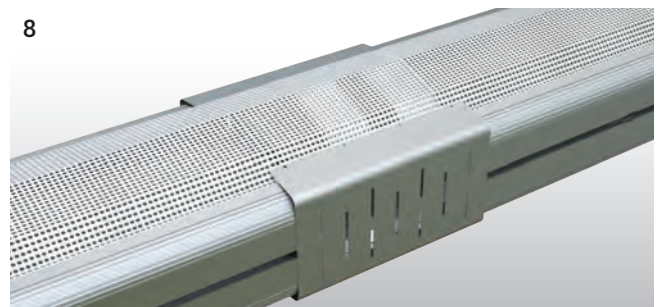

Joint protection pieces of perforated aluminium should be fitted.

E-LINE MV

Vertical Application

1

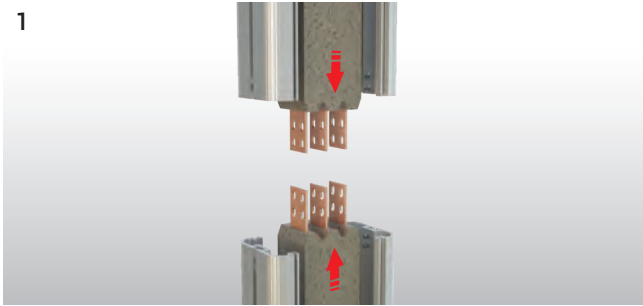

The ends of the conductors of the busbars are cleaned with a clean dry cloth. The busbars have to be fixed in the same axis, with a max. distance of 10 mm between the two conductors.

3

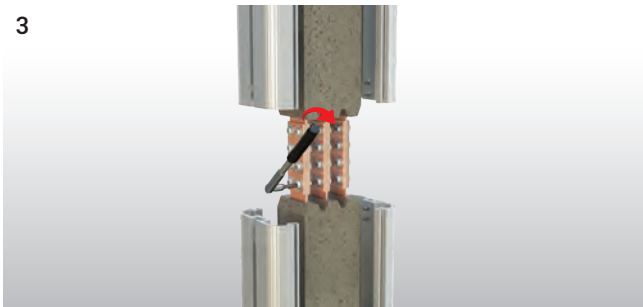

All bolts must be tightened to 72 Nm with torque wrench.

5

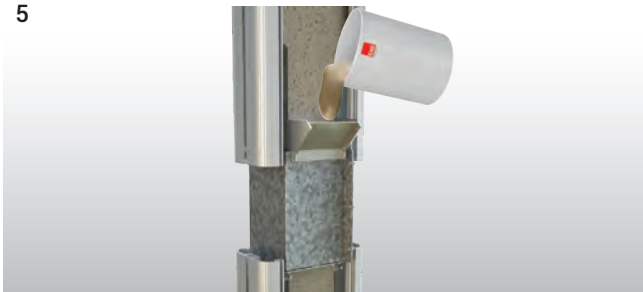

The prepared for casting should be cast from the same spot at all times.

7

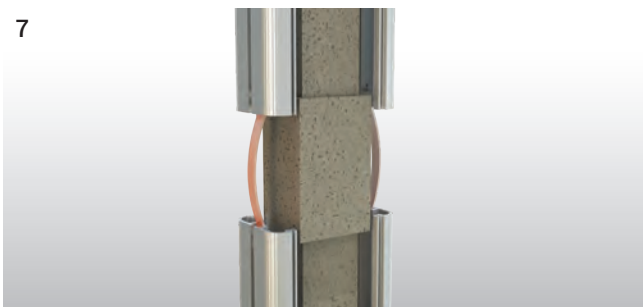

After the curing of the cast material is complete the sheet metal moulds can be removed. (Reaction is completed within 8 - 24 hours based on the air temperature.) The flexibles are fitted to the profiles grooves for earth continuity.

2

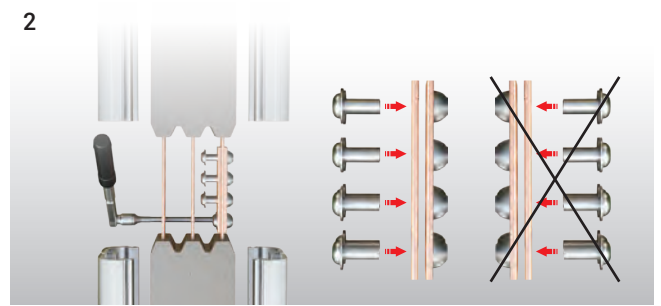

As shown on the figure, junction plates fixed as the bolts face the same direction at all times.

4

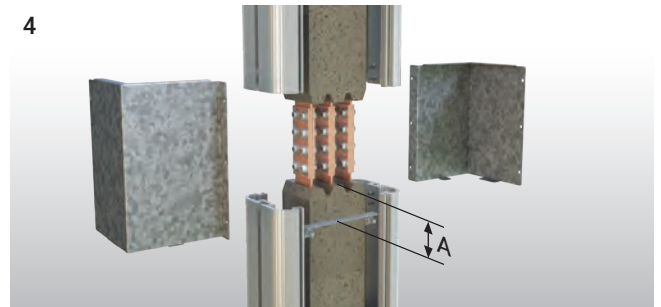

Support sheets are secured on the lower part of juncture area by stem bar. A min. 50-60 mm. The joint moulds are affixed on the support sheet by cleaning with a dry and clean piece of cloth.

6



The material should be "vibrated" with the help of a plastic hammer to remove the air in the material. Then the air bubbles on the surface have to be brushed.

8

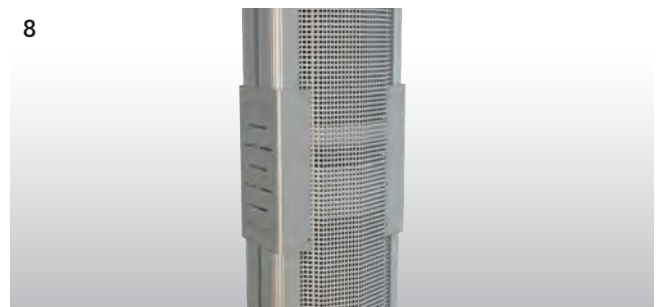

Joint protection pieces of perforated aluminium should be fitted.

950 A TO 2750 A MEDIUM VOLTAGE BUSBAR SYSTEMS (E- LINE MV) GENERAL PRODUCT SPECIFICATIONS

1- Standards & Certification:

-Busbar trunking system shall be designed in accordance with the international standards IEC 62271-200 and IEC 61439-6, type tests thereof shall be conducted and manufactured in accordance with the standard. Type tests shall be conducted by independent and accredited testing and certification bodies with international validity and certified accordingly. Short-circuit type tests and the following 3 main type tests shall be conducted for each current rating of busbar system and conformity certificate for the standards shall be obtained.

2- Overall System Structure

Busbar system should be with low impedance complying with the following specifications. This should be accomplished by placement of the tin coated conductors within the material with no entrapped air within.

2.1- Electrical Values

- Nominal insulation voltage of 12kV busbar trunking system should be 28kV.
- For the tin coated copper, the environmental temperature should be maximum 40 °C while the maximum temperature rise should be 90 K.
- Busbar trunking 3 sec. encryption must be required.
- Minimum short circuit values of busbar should be as follows

For Cu Conductors;

950-2750A : phase-phase 1 sec. value 25kA, peak value 65kA

2.2- Housing and Overall Structure

- Housing of busbar lengths is a special design and should be manufactured from a cast material.
- The structure of the busbar lengths shall have tin plated conductors along their complete length within the housing.
- In the busbar trunking system, there should be down-up and right-left turning elements, panel, transformer and cable connection elements, closure, horizontal and vertical expansion elements as a standard. Special modules and special size busbar lengths that may be required during the implementation of the project should be able to be manufactured within a short time and in accordance with the standard specification and technique.
- If busbar runs pass through the building expansion joint a horizontal expansion element shall be used in the run. Besides, horizontal dilatation element should be used at each 40 m on the horizontal lines.

2.3- Conductors and Phase Configuration

- Busbar trunking systems conductors shall be high conductivity copper with 99.95% / 99.99% between 950-2750A.
- Busbar trunking system should be in the following conductor number and phase configuration

a) 3 Conductors / PE housing

- Copper conductors should be 99.95% electrolytic copper. Minimum conductivity value should be 56 m/mm². Entire surfaces of the electrolytic copper conductors should be tin-coated.

2.4- Insulation Structure

- High conductivity bars; It must be insulated with a special composite material formed by a mixture of specially selected sand, calcite and epoxy resin. This material should be suitable for temperature changes and thermal expansion. High protection should be provided against external impacts.
- Insulation structure must be such that it can operate at -70 + 150 ° C.

2.5- Modular Joint Structure

- The phase conductors shall be joined using two junction plates per phase of suitable cross section to maintain the rating integrity of the conductors. These plates shall be secured using bolts with non-sharp tips torqued to 72 Nm. The joint shall be completed using a mixture of epoxy and silicon to match the material of the busbar lengths. This material should be compliant with temperature changes and thermal expansion. It should ensure high protection against external impacts. Juncture point bolts should be tightened with torque wrench set to 72 Nm (55 lbft)

3- Assembly and Commissioning Tests

- The assembly of the busbar trunking system should be performed in accordance with the electrical project , electrical single line diagram, layout plans and detailed busbar application projects in line with the type and current values indicated on these plans, instructions provided by the manufacturer should be strictly abided with during the assembly process. Joint bolts shall definitely be tightened by the torque wrench set to correct values and insulated accordingly.
- Upon the completion of the assembly of the busbar system and controlling of the compliance to the project thereof and assembly instructions;

- a) Di-Electric test with very low frequency should be conducted.
- b) Joint resistances and Line resistances should be measured.
- c) Phase sequences should be checked.

ПромМашТест
PROMMASHTEST LIMITED COMPANY
Test Center
Principal Place of Business of the Legal Entity: 119530, Moscow city, Otkhovskoy Road, Apt 34, Office VII/5
(119530, город Москва, дом 34, помещение VII, комната 6)
Low-Voltage Equipment Test Laboratory
Address in where the accreditation activity is executed: 142300 Moscow city, Chehovskiy District, Chehov town,
Simferopol road, Apt.2
(142300 Московская область, Чеховский район, Симферопольское шоссе, д.2)
APPROVAL
PROMMASHTEST Test Center Director
S.A. Egorov
28.11.2019
Partial reproduction and distribution of the protocol is strictly prohibited without the written authorization of PROMMASH TEST Limited Company.
Test results indicated on this protocol are only valid for the samples tested.

DEKRA
DEKRA TEST REPORT 2221727.05-MHV Page 1 of 53
Applicant : EAE Elektrik Asansör End. İnsaat San. ve Tic. A.Ş., Akçaburgaz Mahallesi 119, Sokak No: 10 34510 Esenyurt / İstanbul Turkey
Application Date : 23 October 2017
Order Number : 222172700
Product : Medium-voltage busbar trunking system (busway)
Trade name : EAE
Type/Model : MVC 1211
Amhem, 28 February 2018
Manufacturer : EAE Elektrik Asansör End. İnsaat San. ve Tic. A.Ş., Akçaburgaz Mahallesi 119, Sokak No: 10 34510 Esenyurt / İstanbul Turkey
Subject : Design verification
Requirements : IEC 62271-200 Edition 2.0 2011-10 IEC 61439-6 Edition 1.0 2014-05 IEC 62271-307 Edition 1.0 2015-09 STL Guide to IEC 62271-200 Edition 2.0 2011-10
Conclusion : The product complies with the specified requirements
Tested by : M. Lusing
Checked by : A.D.J. Baas

DEKRA
DEKRA TEST REPORT 2221727.05-MHV Page 1 of 53
Applicant : EAE Elektrik Asansör End. İnsaat San. ve Tic. A.Ş., Akçaburgaz Mahallesi 119, Sokak No: 10 34510 Esenyurt / İstanbul Turkey
Application Date : 23 October 2017
Order Number : 222172700
Product : Medium-voltage busbar trunking system (busway)
Amhem, 28 October 2018
Manufacturer : EAE Elektrik Asansör End. İnsaat San. ve Tic. A.Ş., Akçaburgaz Mahallesi 119, Sokak No: 10 34510 Esenyurt / İstanbul Turkey
Subject : Design verification
Requirements : IEC 62271-200 Edition 2.0 2011-10 IEC 61439-6 Edition 1.0 2014-05 IEC 62271-307 Edition 1.0 2015-09 STL Guide to IEC 62271-200 Edition 2.0 2011-10
Conclusion : The product complies with the specified requirements
Tested by : M. Lusing
Checked by : A.D.J. Baas
MLU : 0011-18

DEKRA
DEKRA TEST REPORT 2221727.05-MHV Page 1 of 53
Applicant : EAE Elektrik Asansör End. İnsaat San. ve Tic. A.Ş., Akçaburgaz Mahallesi 119, Sokak No: 10 34510 Esenyurt / İstanbul Turkey
Application Date : 23 June 2018
Order Number : 222982100
Product : Medium-voltage busbar trunking system (busway)
Amhem, 28 November 2018
Manufacturer : EAE Elektrik Asansör End. İnsaat San. ve Tic. A.Ş., Akçaburgaz Mahallesi 119, Sokak No: 10 34510 Esenyurt / İstanbul Turkey
Subject : Design verification
Requirements : IEC 62271-200 Edition 2.0 2011-10 IEC 61439-6 Edition 1.0 2014-05 IEC 62271-307 Edition 1.0 2015-09 STL Guide to IEC 62271-200 Edition 2.0 2011-10
Conclusion : The product complies with the specified requirements
Tested by : M. Lusing
Checked by : A.D.J. Baas
MLU : 18-0465

DEKRA
DEKRA TEST REPORT 2221727.05-MHV Page 1 of 53
Applicant : EAE Elektrik Asansör End. İnsaat San. ve Tic. A.Ş., Akçaburgaz Mahallesi 119, Sokak No: 10 34510 Esenyurt / İstanbul Turkey
Application Date : 23 June 2018
Order Number : 222982100
Product : Medium-voltage busbar trunking system (busway)
Amhem, 28 November 2018
Manufacturer : EAE Elektrik Asansör End. İnsaat San. ve Tic. A.Ş., Akçaburgaz Mahallesi 119, Sokak No: 10 34510 Esenyurt / İstanbul Turkey
Subject : Design verification
Requirements : IEC 62271-200 Edition 2.0 2011-10 IEC 61439-6 Edition 1.0 2014-05 IEC 62271-307 Edition 1.0 2015-09 STL Guide to IEC 62271-200 Edition 2.0 2011-10
Conclusion : The product complies with the specified requirements
Tested by : M. Lusing
Checked by : A.D.J. Baas
MLU : 18-0465

DEKRA
DEKRA TEST REPORT 2229821.04-MHV Page 1 of 53
Applicant : EAE Elektrik Asansör End. İnsaat San. ve Tic. A.Ş., Akçaburgaz Mahallesi 119, Sokak No: 10 34510 Esenyurt / İstanbul Turkey
Application Date : 29 June 2018
Order Number : 222982100
Product : Medium-voltage busbar trunking system (busway)
Amhem, 28 October 2018
Manufacturer : EAE Elektrik Asansör End. İnsaat San. ve Tic. A.Ş., Akçaburgaz Mahallesi 119, Sokak No: 10 34510 Esenyurt / İstanbul Turkey
Subject : Design verification
Requirements : IEC 62271-200 Edition 2.0 2011-10 IEC 61439-6 Edition 1.0 2014-05 IEC 62271-307 Edition 1.0 2015-09 STL Guide to IEC 62271-200 Edition 2.0 2011-10
Conclusion : The product complies with the specified requirements
Tested by : M. Lusing
Checked by : A.D.J. Baas
MLU : 18-0465

E-LINE MV

Order Code System

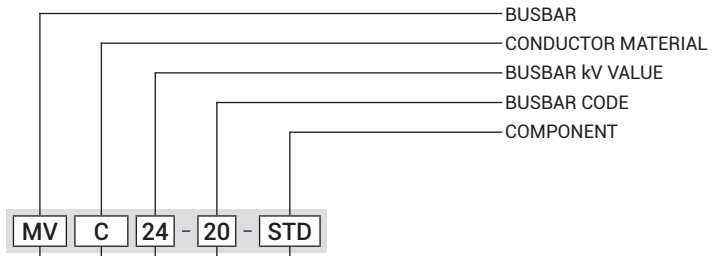

Busbar Type

Copper (Cu) C
CONDUCTOR MATERIAL

BUSBAR kV VALUE	Code	Conductor Configuration		
		L1	L2	L3
17,5kV	24	✓	✓	✓

(* Please call us for different kV values.

MVC - Cu Conductor		Conductor Cross Section
Rated Current	Busbar Code	
1800	18	7x70
2100	21	7x75
3200	32	12x100
4000	40	12x150
5000	50	12x200
5700	57	15x200

- Standard Straight Length.....STD
 Special Straight Length.....X
-
- Upwards Elbow.....U
 Downwards Elbow.....D
 Left Elbow.....L
 Right Elbow.....R
 Panel Connection.....P10

► Copper Conductor (Cu)

Rated Current	I_r	A	1800	2100	3200	4000	5000
Busbar Code			18	21	32	40	50
Standards	IEC 62271-200 Edition 2.0 2011-10; IEC 62271-307 Edition 1.0 2015-09; 2.0 2011-10		IEC 61439-6 Edition 1.0 2012-05; STL Guide to IEC 62271-200 Edition 2.0 2011-10				
Rated Voltage	U_r	kV	24	24	24	24	24
Rated power frequency withstand voltage	U_d	kV	50	50	50	50	50
Rated impulse withstand voltage	U_p	kV	125	125	125	125	125
Rated Frequency	f_r	Hz	50	50	50	50	50
Partial Discharge		pC	< 20	< 20	< 20	< 20	< 20
External Mechanical Impacts (IK Code)*	50J, > IK10						
Rated Short-time Withstand Current (1s)	I_k	kA_{rms}	65	65	90,7	90,7	90,7
Rated Peak Withstand Current	I_{ke}	kA	169	169	236	236	236
Rated Short-time Withstand Current for PE Conductor (1s)	I_p	kA	39	39	55,7	55,7	55,7
Rated Peak Withstand Current for PE Conductor	I_{pe}	kA	102	102	144	144	144
MEAN PHASE CONDUCTOR CHARACTERISTICS AT RATED CURRENT I_n							
Resistance at a conductor temperature of 20°C	R_{20}	mΩ/m	0,0425	0,0401	0,0210	0,0126	0,0100
Resistance at an ambient air temperature of 35°C	R	mΩ/m	0,0568	0,0547	0,0289	0,0172	0,0138
Reactance (Independent from Temperature)	X	mΩ/m	0,1343	0,1303	0,1084	0,0879	0,0806
Positive and negative sequence impedances at an ambient air temperature of 35°C	Z	mΩ/m	0,1458	0,1413	0,1121	0,0896	0,0818
Positive and negative sequence impedances at an ambient air temperature of 20°C	Z_{20}	mΩ/m	0,1408	0,1363	0,1104	0,0888	0,0813
Rated Power Loss at 35°C		Watt	529	703,3	867,3	797,5	1010,5
DC Resistance at a conductor temperature of 20 °C for Phases	R_{phdc}	mΩ/m	0,034	0,034	0,017	0,012	0,009
DC Resistance at a conductor temperature of 20°C for PE	R_{PEdc}	mΩ/m	0,009	0,009	0,009	0,006	0,013
SECTIONS							
Phase Conductor		mm ²	490	525	1200	1800	2400
PE (Housing)		mm ²	8515	8515	8515	9394	10194
Conductor Cross Section		mm x mm	7x70	7x75	12x100	12x150	12x200
Busbar Weight (3 Conductors)		kg/m	104	106	122	152	187
MEAN FAULT-LOOP CHARACTERISTICS							
Zero-sequence Impedance							
Zero-sequence impedance at a conductor temperature of 20°C	$Z_{(0)b20phPE}$	mΩ/m	0,269	0,253	0,220	0,211	0,192
Zero-sequence impedance at an ambient temperature of 35°C	$Z_{(0)bphPE}$	mΩ/m	0,284	0,253	0,230	0,220	0,199
Mean Resistances and Reactances							
Resistance at a conductor temperature of 20°C	$R_{b20phph}$	mΩ/m	0,089	0,055	0,047	0,032	0,025
Resistance at a conductor temperature of 20°C	$R_{b20phPE}$	mΩ/m	0,062	0,056	0,041	0,033	0,026
Resistance at an ambient air temperature of 35°C	R_{bphph}	mΩ/m	0,119	0,075	0,046	0,044	0,035
Resistance at an ambient air temperature of 35°C	R_{bphPE}	mΩ/m	0,083	0,076	0,041	0,045	0,036
Reactance (Independent from temperature)	X_{bphph}	mΩ/m	0,264	0,246	0,209	0,170	0,143
Reactance (Independent from temperature)	X_{bphPE}	mΩ/m	0,169	0,156	0,142	0,122	0,108

Standards

⁽¹⁾The weight per metre provided in table includes 1/3 of the weight of one block joint.

E-LINE MV

Standard Straight Length



► Standard Feeder Straight Length

STD

Sample Order:

MVC 2418 - STD
17,5kV 1800 A, Copper,
Feeder, 3 Conductors

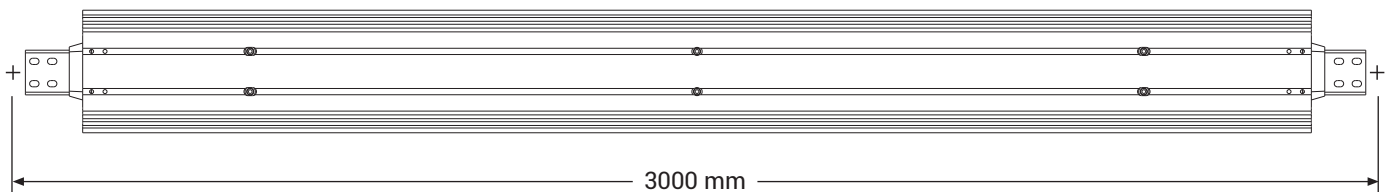
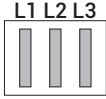

► Special Feeder Straight Length

X

Sample Order:

MVC 2432 - X - 150
17,5kV 3200 A, Copper, Feeder,
3 Conductors, 1500 mm Special Length

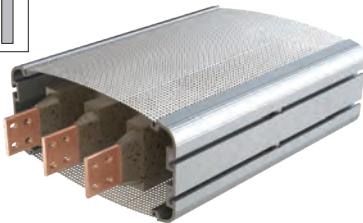
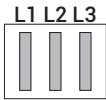

Information:
Feeder Minimum
Special length size = 1000 mm

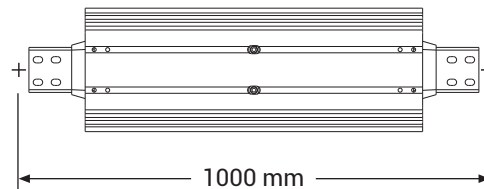

► Table For Outer Dimension of Busbars

MVC - Cu Conductor	Conductor Cross Section	7x70	7x75	12x100	12x150	12x200	15x200
	Rated Current (A)	1800	2100	3200	4000	5000	5700
	Busbar Code	18	21	32	40	50	57
A	mm	160	160	160	210	260	260
B	mm	247	247	247	297	347	347

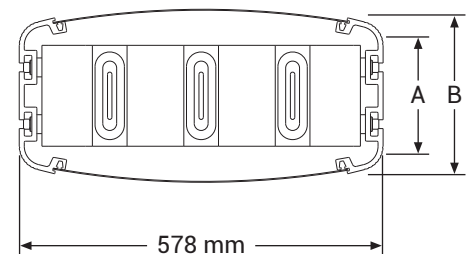

Attention ! The standard mounting of the MV busbar is with the conductors on edge. This allows for the easy application of the resin at the joint.

E-LINE MV

Elbows



► Upwards Downwards Elbow

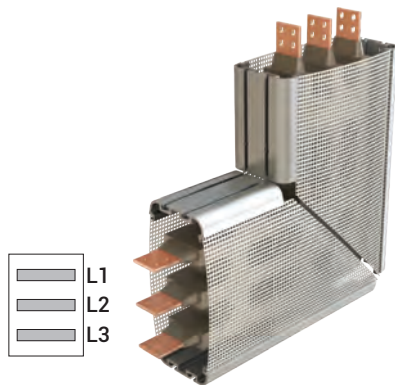

U
D

Sample Order:

MVC 2421 - U
17,5kV 2100 A, Copper, Feeder,
3 Conductors

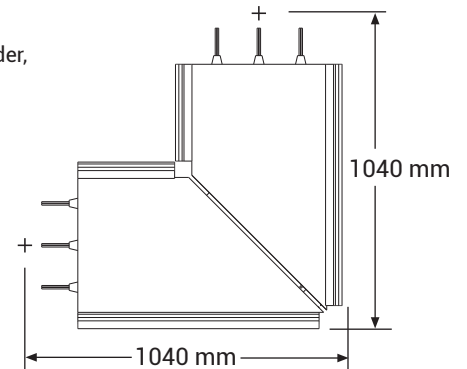

► Left Right Elbow

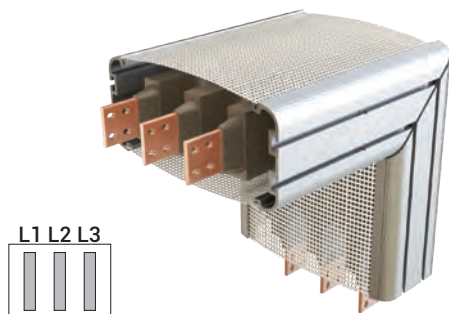

R
L

Sample Order:

MVC 2432 - R
17,5kV 3200 A, Copper, Feeder,
3 Conductors

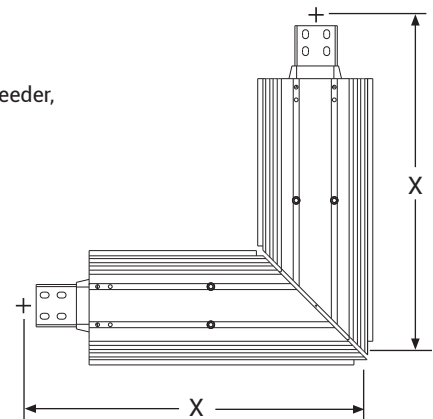

► Table of Busbar Cross Section Sizes

MVC - Cu Conductor	Conductor Cross Section	7x70	7x75	12x100	12x150	12x200	15x200
	Rated Current (A)	1800	2100	3200	4000	5000	5700
	Busbar Code	18	21	32	40	50	57
X	mm	690	690	690	740	790	790

► Panel Connection

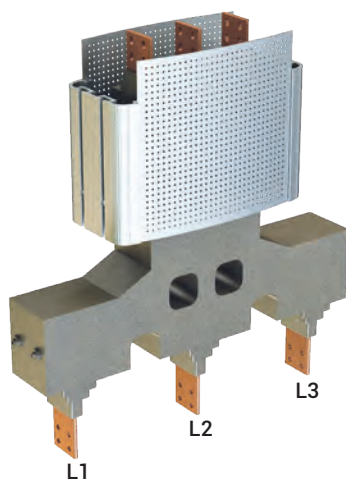

P10
T10

Sample Order:

MVC 2450 - P10
17,5kV 5000 A, Copper,
Feeder, 3 Conductors
For Panel Feeder

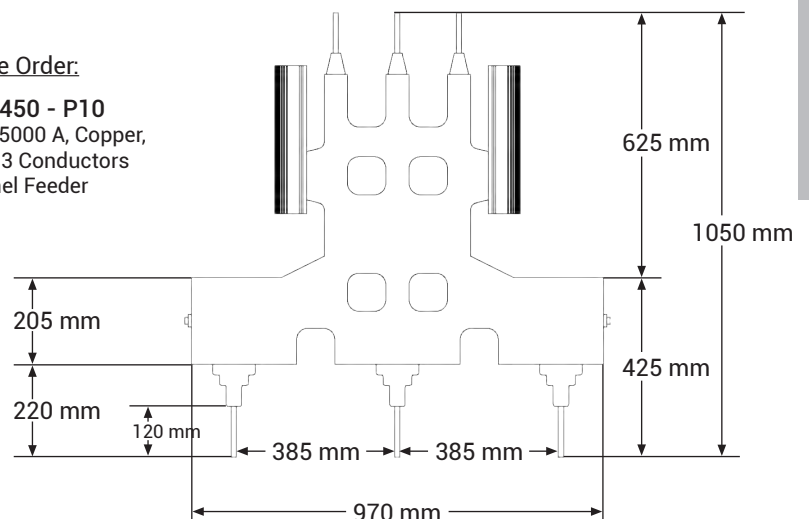

17,5 kV

E-LINE MV

Horizontal & Vertical Cast Resin Busbar Applications



FIGURE 1 - EDGEWISE APPLICATION

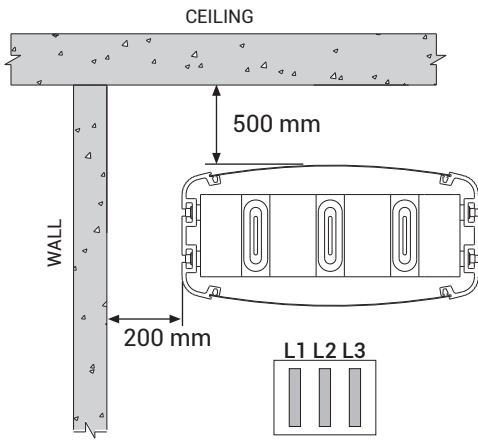

FIGURE 4 - SAMPLE WALL CROSSING WITH FIRE BARRIER

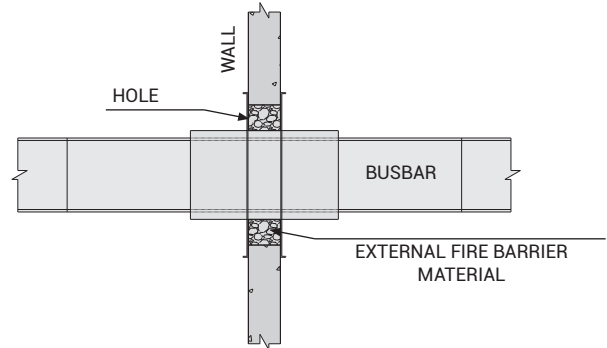
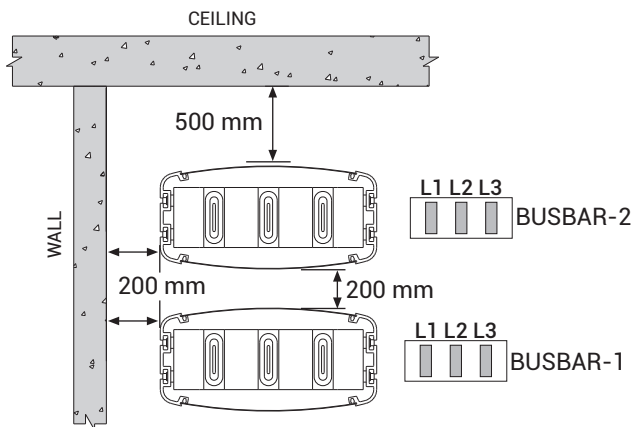

FIGURE 2 - EDGEWISE APPLICATION



Primarily on the installation phase; BUSBAR-1 line should be installed before BUSBAR-2 line.

FIGURE 5 - STANDARD WALL CROSSING

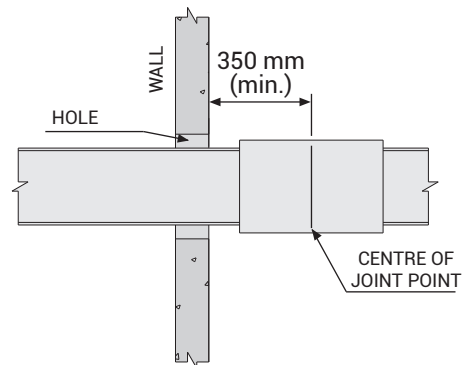
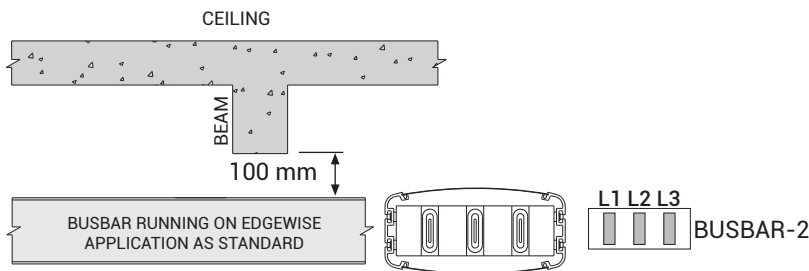

FIGURE 3 - CROSSING UNDER A BEAM ON EDGEWISE APPLICATION



⚠ Attention !

- For correct installation, the dimension from the busbar to the ceiling should not be less than 500mm.
- The joint should be not come across to Beams.
- The dimensions given above are minimum values.
- All dimensions are given in mm.

► Cast Resin Installation Tools

Description	Order Code
CR Joint Area Mixer	5000132
CR Plastic Hammer	5000310
CR Spoon Brush	5000311
MV Allen Torque Set	5000664
Disposable Coverall	5003622



E-LINE MV

Trunking Support

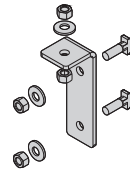
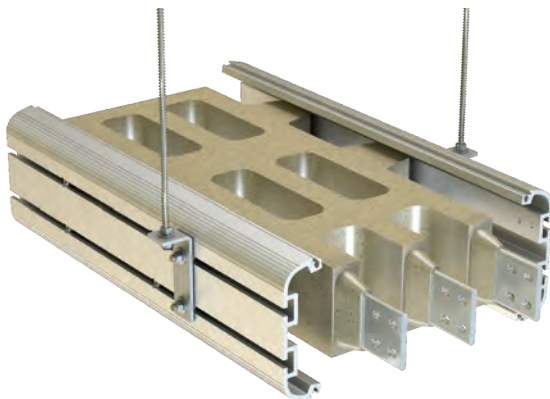

MV L Hanger Set
Ø13 / Ø17-(90-110-160)

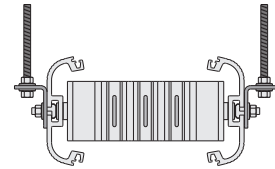

► MV "L" Hanger Set Code

MVC - Cu Conductor		Conductor Dimensions	MV "L" Hanger Set Code			
Rated Current	Busbar Code		Description	Order Code	Description	Order Code
1800	18	7x70	MV L HANGER SET Ø13-(90)	3180150	MV L HANGER SET Ø17-(90)	3180153
2100	21	7x75			MV L HANGER SET Ø17-(110)	3180154
3200	32	12x100	MV L HANGER SET Ø13-(110)	3180151	MV L HANGER SET Ø17-(110)	3180154
4000	40	12x150			MV L HANGER SET Ø17-(160)	3180155
5000	50	12x200	MV L HANGER SET Ø13-(160)	3180152	MV L HANGER SET Ø17-(160)	3180155
5700	57	15x200				

Note: Ø17 Panel Connection for Special Suspension.
It is not included in the rod hanger set.

► 17,5kV Additional Zone Weights

MVC - Cu Conductor		Conductor Dimensions	Weight (kg)
Rated Current	Busbar Code		
1800	18	7x70	36,0
2100	21	7x75	36,0
3200	32	12x100	34,0
4000	40	12x150	41,5
5000	50	12x200	48,0
5700	57	15x200	48,0

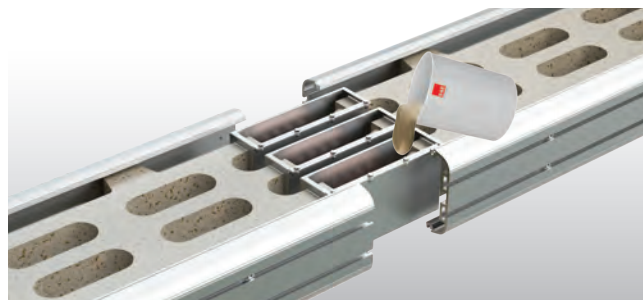

Total mixture weight of 1 Bucket is 15 kg

● When determining the material to be consumed for joint point, the installation of joint point weighing 15 kg and its multiples should be included in the work plan for the same day. Otherwise, since the remaining material will happen a curing reaction, it cannot be used in another day's work plan and will be scrapped. Material planning should be done taking this detail into consideration.

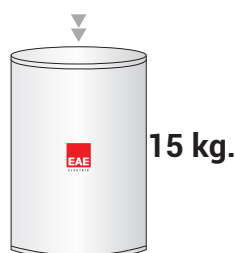

17,5 kV

E-LINE MV

Trunking Support

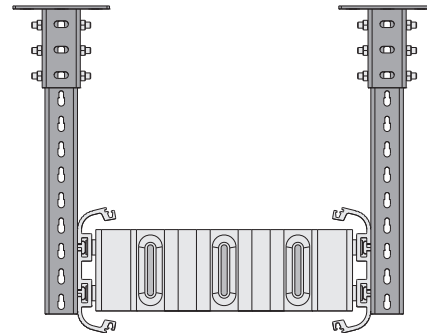
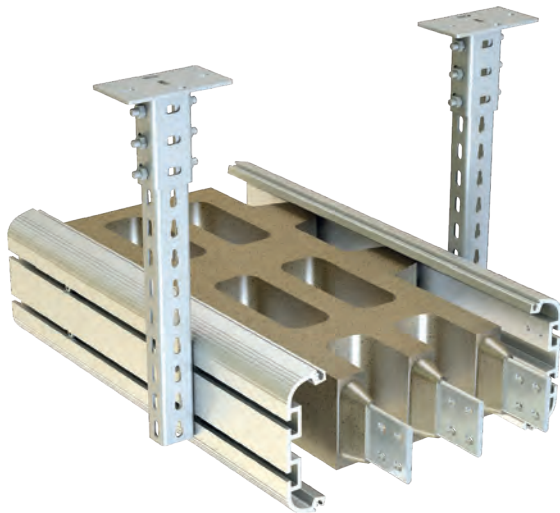

► Ceiling Fixing Element

Description	T (mm)	Tensile Load (kg.)	Weight (kg./pcs)	Order Code	Pack (pcs)
TMP 3	4	900	1,689	3086554	10

Note: The bolt set is not included in the product.
Please order separately.

TMP 3 Fixing Element Mounting;
6 pcs M10x30 Bolt,
12 pcs M10 Washers,
6 pcs M10 Spring Washers,
6 pcs M10 Nuts
should be used.

► Heavy Duty Supports (U)

Description	T (mm)	L (mm)	Weight (kg./pcs)	Order Code
UPY 150	4	150	0,586	3004486
UPY 300	4	300	1,172	3004487
UPY 400	4	400	1,562	3004489
UPY 500	4	500	1,956	3004491
UPY 600	4	600	2,343	3004493
UPY 700	4	700	2,728	3004495
UPY 800	4	800	3,124	3004496
UPY 900	4	900	3,515	3004497
UPY 1000	4	1000	3,945	3004498
UPY 1100	4	1100	4,296	3004499
UPY 1200	4	1200	4,686	3004500
UPY 1300	4	1300	5,071	3004501
UPY 1400	4	1400	5,467	3004502
UPY 1500	4	1500	5,917	3004503
UPY 1600	4	1600	6,248	3004504
UPY 1700	4	1700	6,633	3004505
UPY 1800	4	1800	7,029	3004506
UPY 1900	4	1900	7,414	3004507
UPY 2000	4	2000	7,811	3004508
UPY 3000	4	3000	11,716	3001954

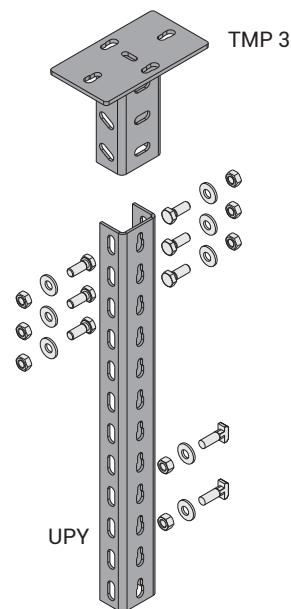

E-LINE MV

Panel Connection



► Two Dimensional Drawings of Panel Modules P10 Panel Mounted Modules

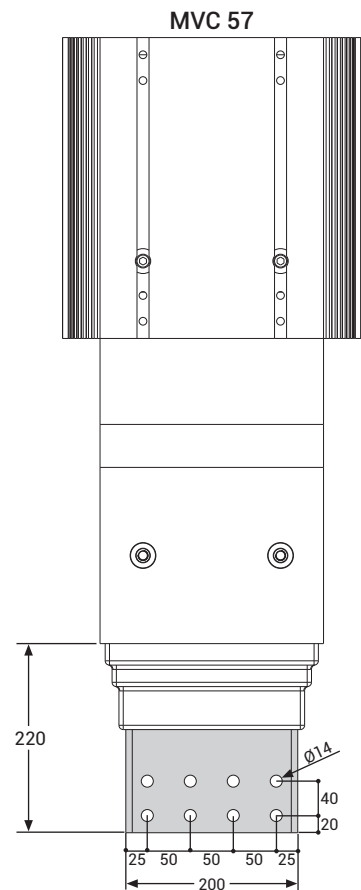
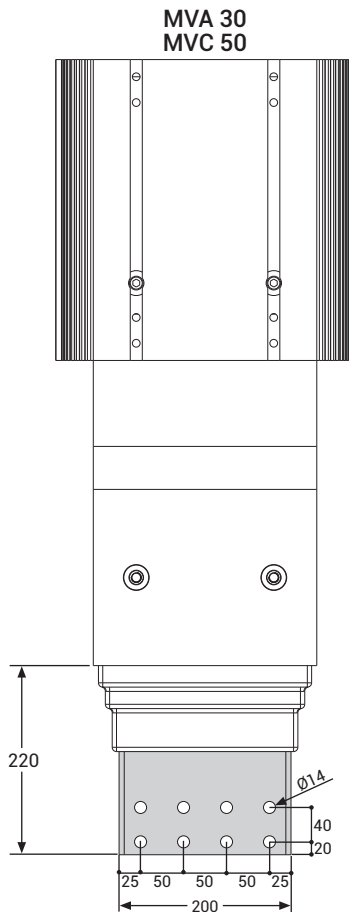
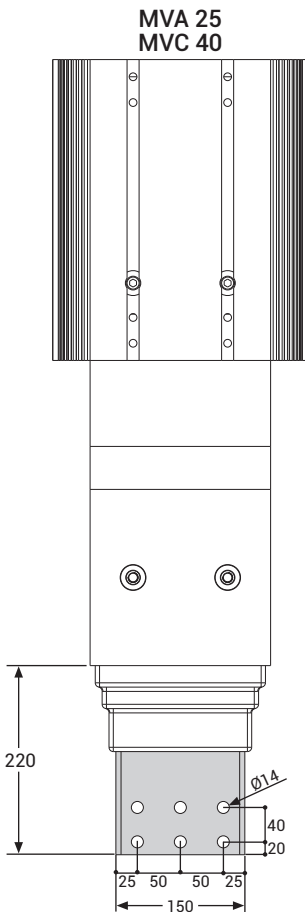
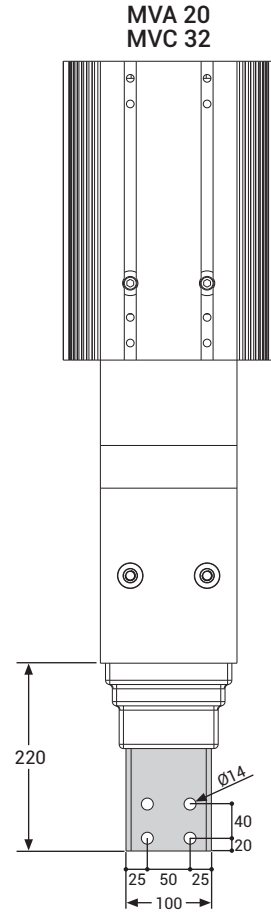
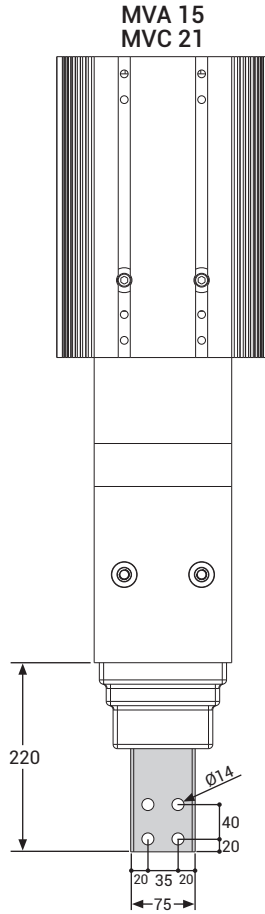
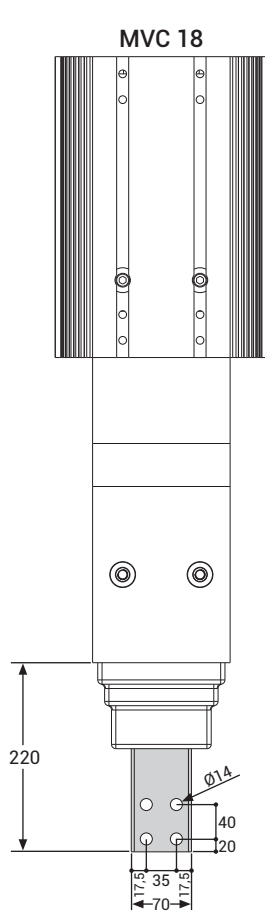

17,5 kV

E-LINE MV

Horizontal Application

1

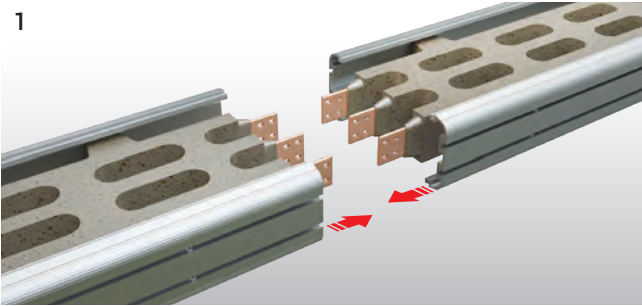

The ends of the conductors of the busbars are cleaned with a clean dry cloth. The busbars have to be fixed in the same axis, with a max. distance of 10 mm between the two conductors.

2

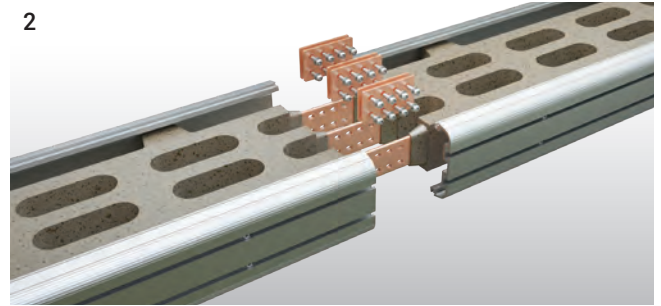

As shown on the figure, junction plates fixed as the bolts face the same direction at all times.

3

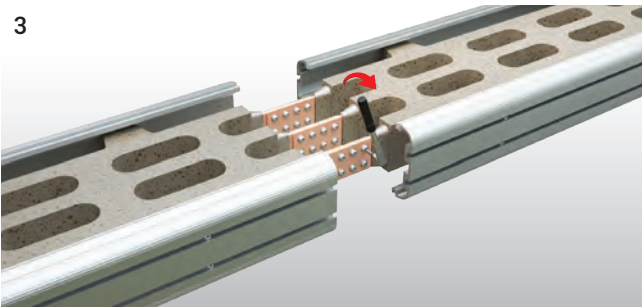

All bolts must be tightened to 72 Nm with torque wrench.

4

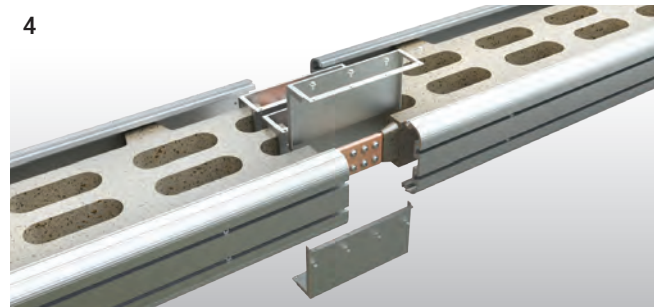

Before assembling the casting moulds, inner surfaces of casting moulds have to be wiped with clean dry cloth.

5



The prepared for casting should be cast from the same spot at all times.

6

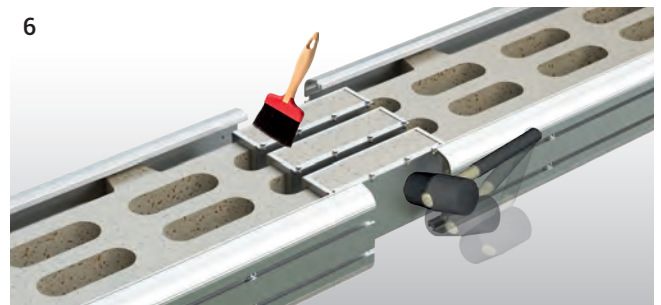

The material should be 'vibrated' with the help of a plastic hammer to remove the air in the material. Then the air bubbles on the surface have to be brushed.

7

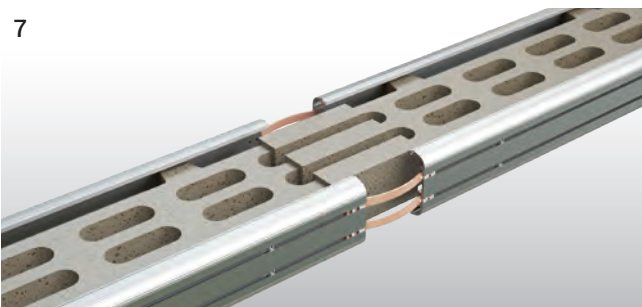

After the curing of the cast material is completed the sheet metal moulds can be removed. (Reaction is completed within 8 - 24 hours based on the air temperature.) The flexibles are fitted to the profiles grooves for earth continuity.

8

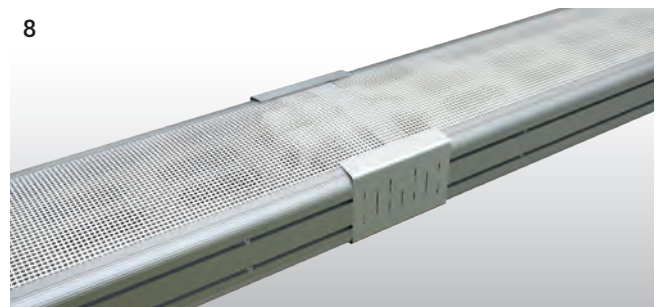

Joint protection pieces of perforated aluminium should be fitted.

E-LINE MV

Vertical Application

1

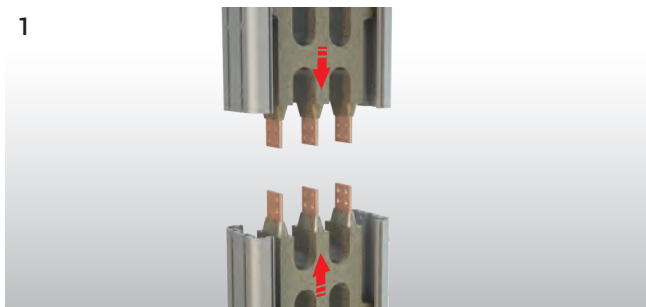

The ends of the conductors of the busbars are cleaned with a clean dry cloth. The busbars have to be fixed in the same axis, with a max. distance of 10 mm between the two conductors.

3

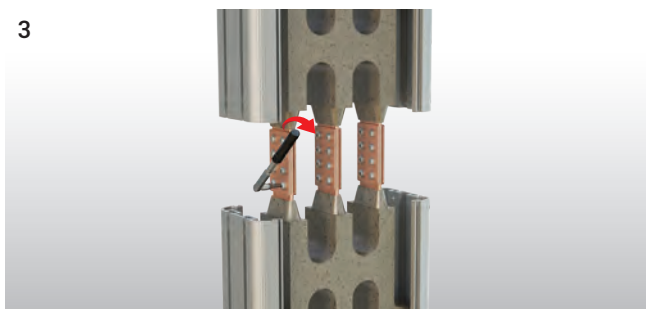

All bolts must be tightened to 72 Nm with torque wrench.

5

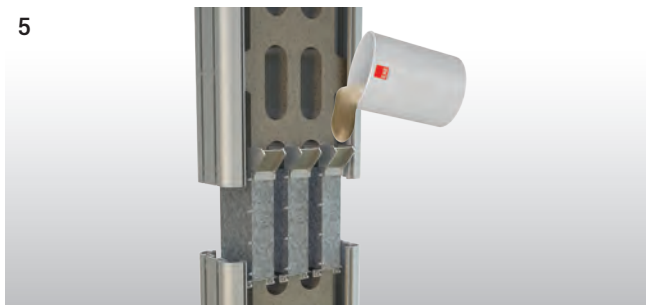

The prepared for casting should be cast from the same spot at all times.

7

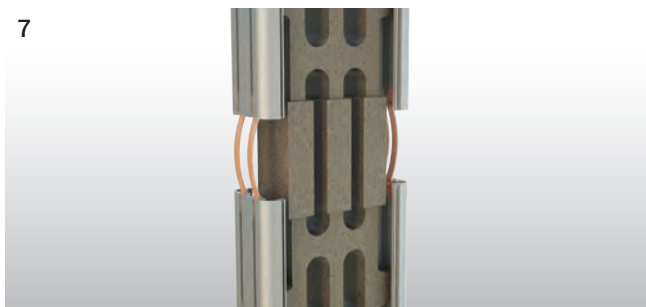

After the curing of the cast material is complete the sheet metal moulds can be removed. (Reaction is completed within 8 - 24 hours based on the air temperature.) The flexibles are fitted to the profiles grooves for earth continuity.

2

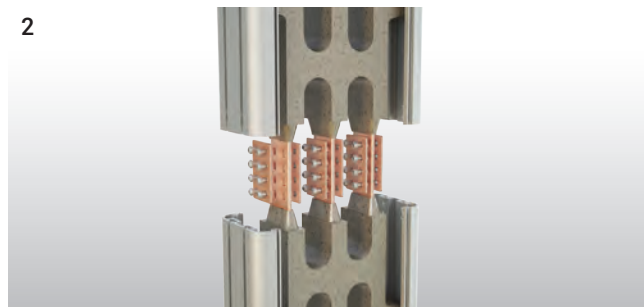

As shown on the figure, junction plates fixed as the bolts face the same direction at all times.

4

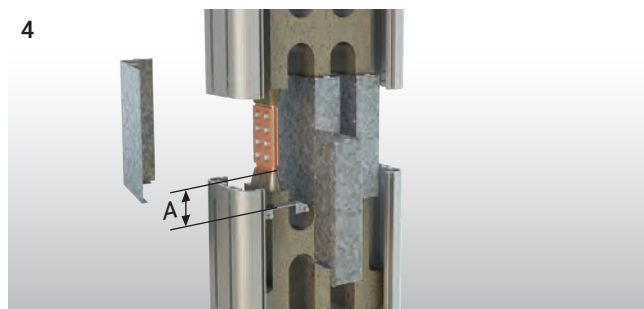

Support sheets are secured on the lower part of junction area by stem bar. A min. 50-60 mm. The joint moulds are affixed on the support sheet by cleaning with a dry and clean piece of cloth.

6

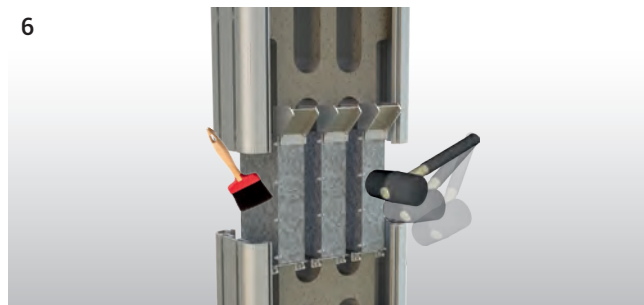

The material should be "vibrated" with the help of a plastic hammer to remove the air in the material. Then the air bubbles on the surface have to be brushed.

8

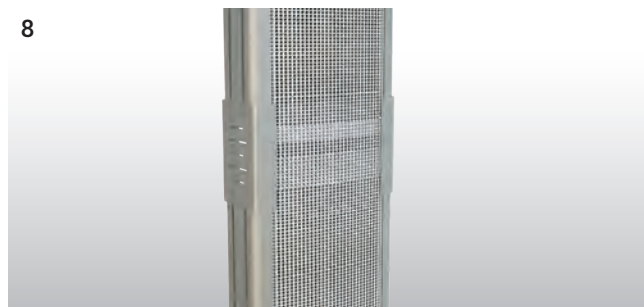

Joint protection pieces of perforated aluminium should be fitted.

1800A TO 5000 A MEDIUM VOLTAGE BUSBAR SYSTEMS (E- LINE MV) GENERAL PRODUCT SPECIFICATIONS

1-Standards & Certification:

- Busbar trunking system shall be designed in accordance with international standards IEC 62271-200 and IEC 61439-6, type tests thereof shall be conducted and manufactured in accordance with the standard. Type tests shall be conducted by independent and accredited testing and certification bodies with international validity and certified accordingly. Short-circuit type tests and the following 3 main type tests shall be conducted for each current rating of busbar system and conformity certificate for the standards shall be obtained.

2-Overall System Structure

Busbar system should be with low impedance complying with the following specifications. This should be accomplished by placement of the tin coated conductors within the material with no entrapped air within.

2.1-Electrical Values

- Nominal insulation voltage of 17,5kV busbar trunking system should be 50kV.
- For the tin coated copper, the environmental temperature should be maximum 40 °C while the maximum temperature rise should be 90 K.
- Busbar channels 3 sec. encryption must be required.
- Minimum short circuit busbar lengths should be as follows.

For Cu Conductors

800-2100 A : phase-phase 1 sec. value 65 kA, peak value 169 kA
3200-5000 A : phase-phase 1 sec. value 72 kA, peak value 187 kA

2.2-Housing and Overall Structure

- Housing of busbar lengths is a special design and should be manufactured from a cast material.
- The structure of the busbar lengths shall have tin plated conductors along their complete length within the housing.
- In the busbar trunking system, there should be down-up and right-left turning elements, panel, transformer and cable connection elements, closure, horizontal and vertical expansion elements as a standard. Special modules and special size busbar lengths that may be required during the implementation of the project should be able to be manufactured within a short time and in accordance with the standard specification and technique.
- If busbar runs pass through the building expansion joint a horizontal expansion element shall be used in the run. In addition horizontal expansion elements should be used at each 40 m on the horizontal lines.

2.3-Conductors and Phase Configuration

- Busbar trunking system should be copper conductive between 1800-5700A.
- Busbar trunking systems conductors shall be high conductivity copper.

a) 3 Conductors / PE housing

- Copper conductors should be 99.99% electrolytic copper. Minimum conductivity value should be 56 m/mm². Entire surfaces of the electrolytic copper conductors should be tin-coated.

2.4- Insulation Structure

- High conductivity bars; It must be insulated with a special composite material formed by a mixture of specially selected sand, calcite and epoxy resin. This material should be suitable for temperature changes and thermal expansion. High protection should be provided against external impacts.
- Insulation structure must be such that it can operate at -70 + 150 ° C.

2.5-Modular Joint Structure

The phase conductors shall be joined using two junction plates per phase of suitable cross section to maintain the rating integrity of the conductors. These plates shall be secured using bolts with non-sharp tips torqued to 72 Nm. The joint shall be completed using a mixture of epoxy and silicon to match the material of the busbar lengths. This material should be compliant with temperature changes and thermal expansion. It should ensure high protection against external impacts. Juncture point bolts should be tightened with torque wrench set to 72 Nm (55 lbft)

3-Assembly and Commissioning Tests

- The assembly of the busbar trunking system should be performed in accordance with the electrical project , electrical single line diagram, layout plans and detailed busbar application projects in line with the type and current values indicated on these plans, instructions provided by the manufacturer should be strictly abided with during the assembly process. Joint bolts shall definitely be tightened by the torque wrench set to correct values and insulated accordingly.
- Upon the completion of the assembly of the busbar system and controlling of the compliance to the project thereof and assembly instructions;
 - Di-Electric test with very low frequency should be conducted.
 - Joint resistances and Line resistances should be measured.
 - Phase sequences should be checked.

ПромМашТест
PROMMASHTEST LIMITED COMPANY
Test Center
Principal Place of Business of the Legal Entity: 119530, Moscow city, Ochakovskoy Road, Apt 34, Office VII/6
(119530, город Москва, дом 34, помещение VII, комната 6)

Low-Voltage Equipment Test Laboratory
Address in where the accreditation activity is executed: 142300 Moscow city, Chehovskiy District, Chehov town,
Simferopol road, Apt.2
(142300 Московская область, Чеховский район, Симферопольское шоссе, д.2)

APPROVAL
PROMMASHTEST Test Center Director
S.A.Egorov
28.11.2019
(Signature)

28/3ILNVOK issue number and dated 28.11.2019
TEST REPORT

Partial reproduction and distribution of the protocol is strictly prohibited without the written authorization of PROMMASH TEST Limited Company.
Test results indicated on this protocol are only valid for the samples tested.

DEKRA
TEST REPORT 2214282,07-MHV Page 1 of 56

Applicant : EAE Elektrik Asansör End.
Insaat San. ve Tic. A.Ş.
Akçaburgaz Mahallesi 119. Sokak No: 10
34510 Esenyurt / İstanbul
Turkey

Application Date : 25 January 2017

Order Number : 219326000-INC

Product : Medium-voltage busbar trunking system (busway)

Trade name : EAE

Type/Model : MVA 2415

Amhem, 6 June 2017

Manufacturer : EAE Elektrik Asansör End.
Insaat San. ve Tic. A.Ş.
Akçaburgaz Mahallesi 119. Sokak No: 10
34510 Esenyurt / İstanbul
Turkey

Subject : Design verification

Requirements : IEC 62271-200 Edition 2.0 2011-10
IEC 61439-6 Edition 1.0 2012-05
IEC 62271-307 Edition 1.0 2015-09
STL Guide to IEC 62271-200 Edition 2.0 2011-10

Conclusion : The product complies with the specified requirements

Tested by : M. Lusing

Checked by : A.D.J. Baas

DEKRA
TEST REPORT 2211702,04-MHV Page 1 of 57

Applicant : EAE Elektrik Asansör End.
Insaat San. ve Tic. A.Ş.
Akçaburgaz Mahallesi 119. Sokak No: 10
34510 Esenyurt / İstanbul
Turkey

Application Date : 23 October 2017

Order Number : 221170200

Product : Medium-voltage busbar trunking system

Trade name : EAE

Type/Model : MAC 2457

Amhem, 26 February 2018

Manufacturer : EAE Elektrik Asansör End.
Insaat San. ve Tic. A.Ş.

DEKRA
TEST REPORT 2214282,07-MHV Page 1 of 56

Applicant : EAE Elektrik Asansör End.
Insaat San. ve Tic. A.Ş.
Akçaburgaz Mahallesi 119. Sokak No: 10
34510 Esenyurt / İstanbul
Turkey

Application Date : 25 January 2017

Order Number : 219326000-INC

Product : Medium-voltage busbar trunking system (busway)

Trade name : EAE

Type/Model : MVA 2415

Amhem, 6 June 2017

Manufacturer : EAE Elektrik Asansör End.
Insaat San. ve Tic. A.Ş.
Akçaburgaz Mahallesi 119. Sokak No: 10
34510 Esenyurt / İstanbul
Turkey

DEKRA
TEST REPORT 2214282,07-MHV Page 1 of 57

Applicant : EAE Elektrik Asansör End.
Insaat San. ve Tic. A.Ş.
Akçaburgaz Mahallesi 119. Sokak No: 10
34510 Esenyurt / İstanbul
Turkey

Application Date : 25 January 2017

Order Number : 219326000-INC

Product : Medium-voltage busbar trunking system (busway)

Trade name : EAE

Type/Model : MVA 2415

Amhem, 6 June 2017

Manufacturer : EAE Elektrik Asansör End.
Insaat San. ve Tic. A.Ş.
Akçaburgaz Mahallesi 119. Sokak No: 10
34510 Esenyurt / İstanbul
Turkey

DEKRA
TEST REPORT 2214282,07-MHV Page 1 of 57

Applicant : EAE Elektrik Asansör End.
Insaat San. ve Tic. A.Ş.
Akçaburgaz Mahallesi 119. Sokak No: 10
34510 Esenyurt / İstanbul
Turkey

Application Date : 25 January 2017

Order Number : 219326000-INC

Product : Medium-voltage busbar trunking system (busway)

Trade name : EAE

Type/Model : MVA 2415

Amhem, 6 June 2017

Manufacturer : EAE Elektrik Asansör End.
Insaat San. ve Tic. A.Ş.
Akçaburgaz Mahallesi 119. Sokak No: 10
34510 Esenyurt / İstanbul
Turkey

DEKRA
TEST REPORT 2214282,07-MHV Page 1 of 56

Applicant : EAE Elektrik Asansör End.
Insaat San. ve Tic. A.Ş.
Akçaburgaz Mahallesi 119. Sokak No: 10
34510 Esenyurt / İstanbul
Turkey

Application Date : 25 January 2017

Order Number : 219326000-INC

Product : Medium-voltage busbar trunking system (busway)

Trade name : EAE

Type/Model : MVA 2415

Amhem, 6 June 2017

Manufacturer : EAE Elektrik Asansör End.
Insaat San. ve Tic. A.Ş.
Akçaburgaz Mahallesi 119. Sokak No: 10
34510 Esenyurt / İstanbul
Turkey

DEKRA
TEST REPORT 2214282,07-MHV Page 1 of 57

Applicant : EAE Elektrik Asansör End.
Insaat San. ve Tic. A.Ş.
Akçaburgaz Mahallesi 119. Sokak No: 10
34510 Esenyurt / İstanbul
Turkey

Application Date : 25 January 2017

Order Number : 219326000-INC

Product : Medium-voltage busbar trunking system (busway)

Trade name : EAE

Type/Model : MVA 2415

Amhem, 6 June 2017

Manufacturer : EAE Elektrik Asansör End.
Insaat San. ve Tic. A.Ş.
Akçaburgaz Mahallesi 119. Sokak No: 10
34510 Esenyurt / İstanbul
Turkey

DEKRA
TEST REPORT 2214282,07-MHV Page 1 of 56

Applicant : EAE Elektrik Asansör End.
Insaat San. ve Tic. A.Ş.
Akçaburgaz Mahallesi 119. Sokak No: 10
34510 Esenyurt / İstanbul
Turkey

Application Date : 25 January 2017

Order Number : 219326000-INC

Product : Medium-voltage busbar trunking system (busway)

Trade name : EAE

Type/Model : MVA 2415

Amhem, 6 June 2017

Manufacturer : EAE Elektrik Asansör End.
Insaat San. ve Tic. A.Ş.
Akçaburgaz Mahallesi 119. Sokak No: 10
34510 Esenyurt / İstanbul
Turkey

DEKRA
TEST REPORT 2214282,07-MHV Page 1 of 57

Applicant : EAE Elektrik Asansör End.
Insaat San. ve Tic. A.Ş.
Akçaburgaz Mahallesi 119. Sokak No: 10
34510 Esenyurt / İstanbul
Turkey

Application Date : 25 January 2017

Order Number : 219326000-INC

Product : Medium-voltage busbar trunking system (busway)

Trade name : EAE

Type/Model : MVA 2415

Amhem, 6 June 2017

Manufacturer : EAE Elektrik Asansör End.
Insaat San. ve Tic. A.Ş.
Akçaburgaz Mahallesi 119. Sokak No: 10
34510 Esenyurt / İstanbul
Turkey

DEKRA
TEST REPORT 2214282,07-MHV Page 1 of 56

Applicant : EAE Elektrik Asansör End.
Insaat San. ve Tic. A.Ş.
Akçaburgaz Mahallesi 119. Sokak No: 10
34510 Esenyurt / İstanbul
Turkey

Application Date : 25 January 2017

Order Number : 219326000-INC

Product : Medium-voltage busbar trunking system (busway)

Trade name : EAE

Type/Model : MVA 2415

Amhem, 6 June 2017

Manufacturer : EAE Elektrik Asansör End.
Insaat San. ve Tic. A.Ş.
Akçaburgaz Mahallesi 119. Sokak No: 10
34510 Esenyurt / İstanbul
Turkey

DEKRA
TEST REPORT 2214282,07-MHV Page 1 of 57

Applicant : EAE Elektrik Asansör End.
Insaat San. ve Tic. A.Ş.
Akçaburgaz Mahallesi 119. Sokak No: 10
34510 Esenyurt / İstanbul
Turkey

Application Date : 25 January 2017

Order Number : 219326000-INC

Product : Medium-voltage busbar trunking system (busway)

Trade name : EAE

Type/Model : MVA 2415

Amhem, 6 June 2017

Manufacturer : EAE Elektrik Asansör End.
Insaat San. ve Tic. A.Ş.
Akçaburgaz Mahallesi 119. Sokak No: 10
34510 Esenyurt / İstanbul
Turkey

DEKRA
TEST REPORT 2214282,07-MHV Page 1 of 56

Applicant : EAE Elektrik Asansör End.
Insaat San. ve Tic. A.Ş.
Akçaburgaz Mahallesi 119. Sokak No: 10
34510 Esenyurt / İstanbul
Turkey

Application Date : 25 January 2017

Order Number : 219326000-INC

Product : Medium-voltage busbar trunking system (busway)

Trade name : EAE

Type/Model : MVA 2415

Amhem, 6 June 2017

Manufacturer : EAE Elektrik Asansör End.
Insaat San. ve Tic. A.Ş.
Akçaburgaz Mahallesi 119. Sokak No: 10
34510 Esenyurt / İstanbul
Turkey

DEKRA
TEST REPORT 2214282,07-MHV Page 1 of 57

Applicant : EAE Elektrik Asansör End.
Insaat San. ve Tic. A.Ş.
Akçaburgaz Mahallesi 119. Sokak No: 10
34510 Esenyurt / İstanbul
Turkey

Application Date : 25 January 2017

Order Number : 219326000-INC

Product : Medium-voltage busbar trunking system (busway)

Trade name : EAE

Type/Model : MVA 2415

Amhem, 6 June 2017

Manufacturer : EAE Elektrik Asansör End.
Insaat San. ve Tic. A.Ş.
Akçaburgaz Mahallesi 119. Sokak No: 10
34510 Esenyurt / İstanbul
Turkey

DEKRA
TEST REPORT 2214282,07-MHV Page 1 of 56

Applicant : EAE Elektrik Asansör End.
Insaat San. ve Tic. A.Ş.
Akçaburgaz Mahallesi 119. Sokak No: 10
34510 Esenyurt / İstanbul
Turkey

Application Date : 25 January 2017

Order Number : 219326000-INC

Product : Medium-voltage busbar trunking system (busway)

Trade name : EAE

Type/Model : MVA 2415

Amhem, 6 June 2017

Manufacturer : EAE Elektrik Asansör End.
Insaat San. ve Tic. A.Ş.
Akçaburgaz Mahallesi 119. Sokak No: 10
34510 Esenyurt / İstanbul
Turkey

DEKRA
TEST REPORT 2214282,07-MHV Page 1 of 57

Applicant : EAE Elektrik Asansör End.
Insaat San. ve Tic. A.Ş.
Akçaburgaz Mahallesi 119. Sokak No: 10
34510 Esenyurt / İstanbul
Turkey

Application Date : 25 January 2017

Order Number : 219326000-INC

Product : Medium-voltage busbar trunking system (busway)

Trade name : EAE

Type/Model : MVA 2415

Amhem, 6 June 2017

Manufacturer : EAE Elektrik Asansör End.
Insaat San. ve Tic. A.Ş.
Akçaburgaz Mahallesi 119. Sokak No: 10
34510 Esenyurt / İstanbul
Turkey

DEKRA
TEST REPORT 2214282,07-MHV Page 1 of 56

Applicant : EAE Elektrik Asansör End.
Insaat San. ve Tic. A.Ş.
Akçaburgaz Mahallesi 119. Sokak No: 10
34510 Esenyurt / İstanbul
Turkey

Application Date : 25 January 2017

Order Number : 219326000-INC

Product : Medium-voltage busbar trunking system (busway)

Trade name : EAE

Type/Model : MVA 2415

Amhem, 6 June 2017

Manufacturer : EAE Elektrik Asansör End.
Insaat San. ve Tic. A.Ş.
Akçaburgaz Mahallesi 119. Sokak No: 10
34510 Esenyurt / İstanbul
Turkey

DEKRA
TEST REPORT 2214282,07-MHV Page 1 of 57

Applicant : EAE Elektrik Asansör End.
Insaat San. ve Tic. A.Ş.
Akçaburgaz Mahallesi 119. Sokak No: 10
34510 Esenyurt / İstanbul
Turkey

Application Date : 25 January 2017

Order Number : 219326000-INC

Product : Medium-voltage busbar trunking system (busway)

Trade name : EAE

Type/Model : MVA 2415

Amhem, 6 June 2017

Manufacturer : EAE Elektrik Asansör End.
Insaat San. ve Tic. A.Ş.
Akçaburgaz Mahallesi 119. Sokak No: 10
34510 Esenyurt / İstanbul
Turkey

E-LINE MV

Project Design Form



Component List		Quantity
Item	Component	

Company :	Name :	Prepared by
Project :	Date :	
Project No :	Signature :	

Please duplicate this page for your own use.



PRODUCT TYPES



BUSBAR ENERGY DISTRIBUTION SYSTEMS



CABLE TRAYS



TROLLEY BUSBAR ENERGY DISTRIBUTION SYSTEMS



INDOOR SOLUTIONS



SUPPORT SYSTEMS

Please visit our website for the updated version of our catalogues.
www.eaeelectric.com



EAE Elektrik A.S.
Head Office

Akcaburgaz Mahallesi,
3114. Sokak, No:10 34522
Esenyurt - Istanbul - TURKEY
Tel: +90 (212) 866 20 00
Fax: +90 (212) 886 24 20

EAE DL 3 Factory
Busbar

Gebze IV Istanbul Makine ve Sanayicileri
Organize Bolgesi, 6. Cadde,
No: 6 41455 Demirciler Koyu,
Dilovası - Kocaeli - TURKEY
Tel: +90 (262) 999 05 55
Fax: +90 (262) 502 05 69

Please visit our website for the updated version of our catalogues.
www.eaeelectric.com



Katalog 35-En. / Rev 11 1000 Pcs. 04/02/2025
N.G.

EAE has full right to make any revisions or changes on this catalogue without any prior notice.