



TUNNEL AND RAIL SYSTEM SOLUTIONS

Energy Distribution Solutions





EAE Group in numbers;



1973
year of foundation

Founded in 1973, EAE Elektrik A.S. being the parent company of EAE Group is a worldwide manufacturer of electrical products.



360.000m²
closed manufacturing
area

Founded : in 1973
Closed Manufacturing Area : 360.000m²
Range of Products : Busbar Power Distribution Systems
Lighting Busbar Systems
Cable Tray Systems
Underfloor Trunking
Trolley Busbar Systems



7
manufacturing
plants

Companies : EAE Elektrik
EAE Aydınlatma
EAE Elektroteknik
EAE Teknoloji
EAE Makine



3
R&D Centers

Number of Plants : 7

"Lean Production" and "Innovative and Customer Driven Product Development" approaches are the key values utilized in designing and manufacturing the product families in compliance with ISO 9001, ISO 14001, OHSAS 18001 and ISO 27001. EAE Elektrik A.S. busbar products are certified by KEMA/DEKRA (Holland), KEMA - KEUR, UL classified laboratories as per IEC 61537-1/6 standards.



150+
countries of export

TUNNEL AND RAIL SYSTEM SOLUTIONS

EAE Products

▶▶ EAE Product Types

- Cable Tray Systems
- Support and Accessory Systems
- Busbar Energy Distribution Systems

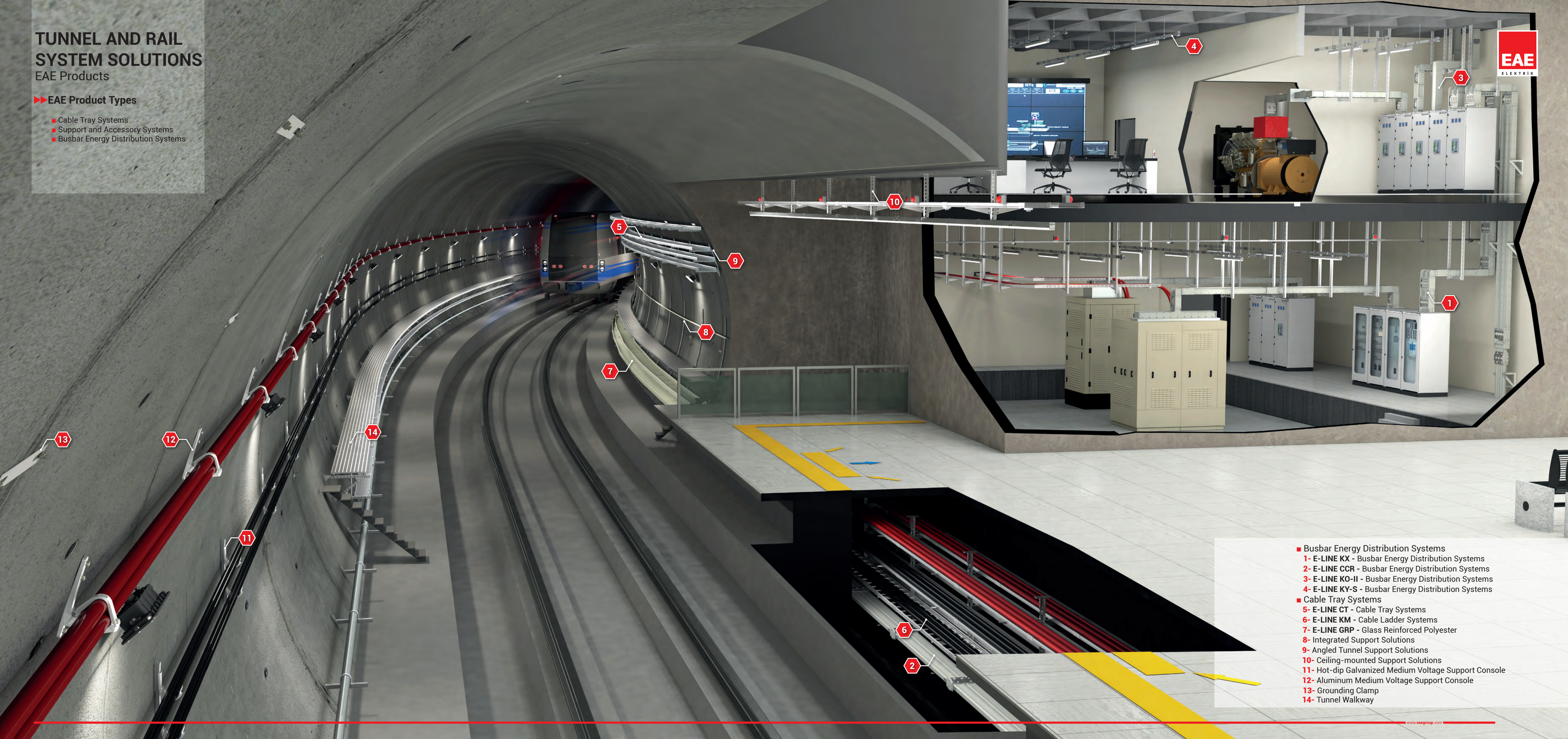

- Busbar Energy Distribution Systems
 - 1- E-LINE KX - Busbar Energy Distribution Systems
 - 2- E-LINE CCR - Busbar Energy Distribution Systems
 - 3- E-LINE KO-II - Busbar Energy Distribution Systems
 - 4- E-LINE KY-S - Busbar Energy Distribution Systems
- Cable Tray Systems
 - 5- E-LINE CT - Cable Tray Systems
 - 6- E-LINE KM - Cable Ladder Systems
 - 7- E-LINE GRP - Glass Reinforced Polyester
 - 8- Integrated Support Solutions
 - 9- Angled Tunnel Support Solutions
 - 10- Ceiling-mounted Support Solutions
 - 11- Hot-dip Galvanized Medium Voltage Support Console
 - 12- Aluminum Medium Voltage Support Console
 - 13- Grounding Clamp
 - 14- Tunnel Walkway

TUNNEL AND RAIL SYSTEM SOLUTIONS

EAE Presents...



- Manufacturing has been ongoing since 1973
- Over 10,000 references; exports to more than 150 countries
- Wide product range
- Installation inspection, and testing in over 150 countries, with more than 150 dealers/sellers

- CB Test Certification
- Kema-Keur Program
- Halogen-Free and Fire-Resistant Products
- ISO 9001, ISO 14001, ISO 45001, ISO 27001, Green Guard and CPR

- Custom-designed products and solutions for projects
- Patented artificial intelligence algorithm based busbar and cable tray software with 3D isometric drawings
- BIM (Building Information Modeling) library

- Fast Production and Delivery
- Emergency production delivery 48 hours
- Easy access from EAE factories to Europe, the Middle East, North Africa, and the Americas

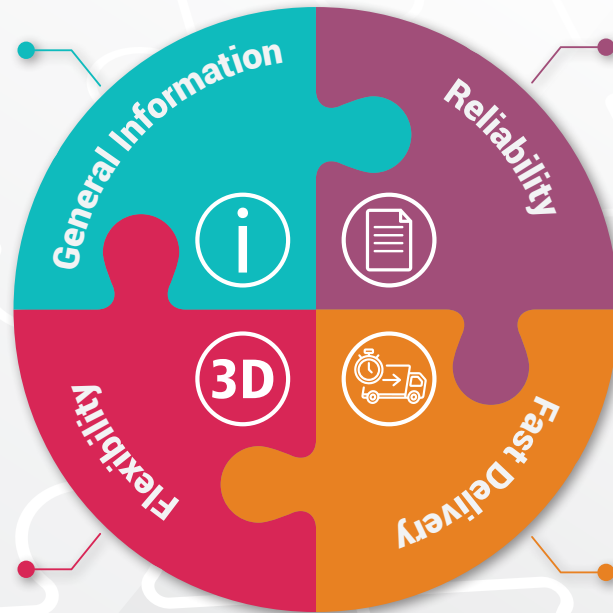

Continuous Innovation



High Standards



Wide Product of Range



Best Prices



Wide Services and Solutions

TUNNEL AND RAIL SYSTEM SOLUTIONS

Certificates

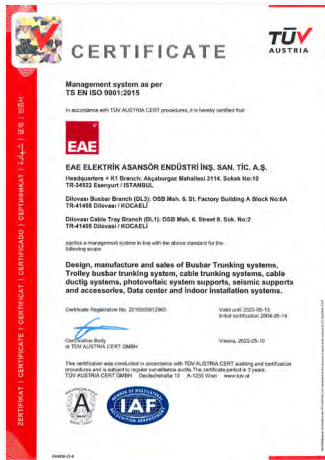

ISO 9001
Quality Management System

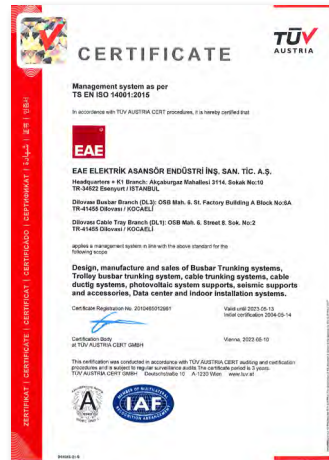

ISO 14001
Environmental Management System



ISO 27001
Information Security Management System



ISO 45001
Occupational Health and Safety Management System



TSE EN 1461
TSE EN 61537



Seismic

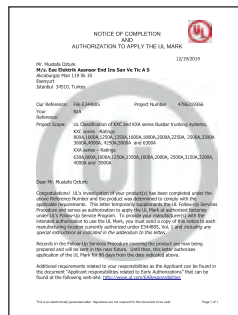

UL Certificate



IEC 61537



DIN 4102-12



TUNNEL AND RAIL SYSTEM SOLUTIONS

EAE Cable Tray Systems



▶▶ E-LINE CT

Hot Dip Galvanized CTE Cable Tray Systems

Genel Introduction

- Heavy duty and regular types
- 40/50/60/75/100/125/150mm tray heights
- 50/100/150/200/250/300/400/500/600 widths (700-800-900 special widths on request)
- 0,8/1/1,2/1,5/2mm thickness
- 3000mm length (6000mm special length on request)
- TS EN ISO 1461 standard hot-dip galvanised
- Possibility to connect the various accessories that 20,5 diametres hole in the middle of the tray
- Wide range of accessories
- Fire resistance certificates (E30-E60-E90)
- Galvanized steel painted finish available on request (epoxy, epoxy polyester, polyester)

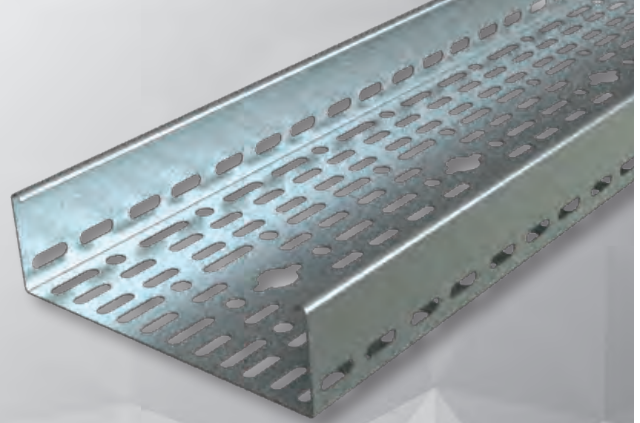

▶▶ E-LINE KME

Hot Dip Galvanized KME Cable Ladders

Genel Introduction

- Heavy duty type
- 40/50/60/75/100/125/150mm heights
- 50/100/150/200/250/300/400/500/600mm widths
- With Binrak traverse with 700/800/900 width options, high bearing capacity (KME)
- 1,2/1,5/2mm thickness
- 300mm equally spaced rung structure
- TS EN ISO 1461 standard hot-dip galvanised
- Wide range of accessories
- Fire resistance certificates (E30-E60-E90)
- Galvanized steel painted finish available on request (epoxy, epoxy polyester, polyester)

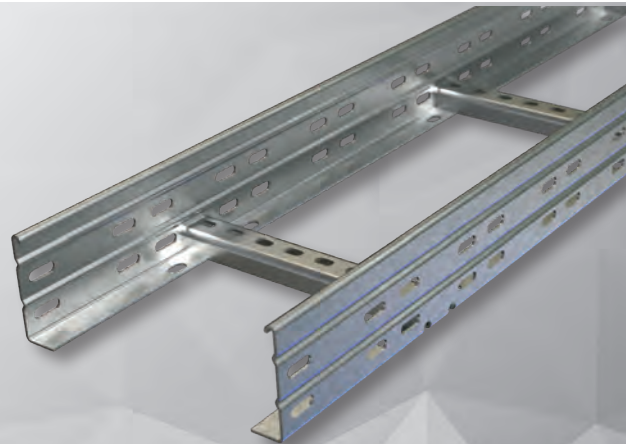

▶▶ E-LINE UKFG

Pre Galvanised Cable Tray Systems

Genel Introduction

- Heavy duty type
- 40/50/60/75/100mm heights
- 100/200/300/400/500/600mm widths
- 100/200/300mm widths 0,7mm and 400/500/600mm widths 0,9mm thicknesses
- Thanks to special forming of the edges of the tray lengths, it can bear the load equal to the products with standard thickness
- Thanks to its snap on system, easily mounted without the need for joint elements
- Wide range of accessories
- Fire resistance certificates (E30-E60-E90)

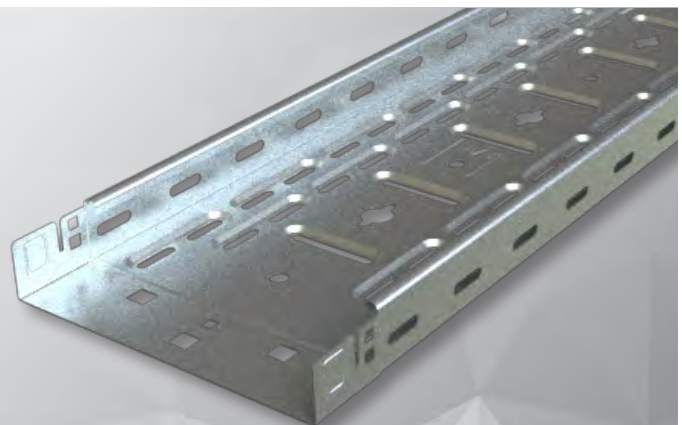

TUNNEL AND RAIL SYSTEM SOLUTIONS

EAE Cable Tray Systems



▶▶ E-LINE UKE

Cable Tray Systems

Genel Introduction

- Heavy duty type
- Standard 40/50/60/75/100mm heights produced
- 50/100/150/200/250/300/400/500/600mm widths
- 0,8/1/1,2/1,5/2mm thickness
- The standard length is 3000mm, It can be produced up to 6000mm upon request.
- According to the TS EN 10346 and TS EN 10143 standards galvanized option (pregalvanized)
- Possibility to connect the various accessories that 20,5 diametres hole in the middle of the tray
- Wide range of accessories
- Fire resistance certificates (E30-E60-E90)
- Galvanized steel painted finish available on request (epoxy, epoxy polyester, polyester)

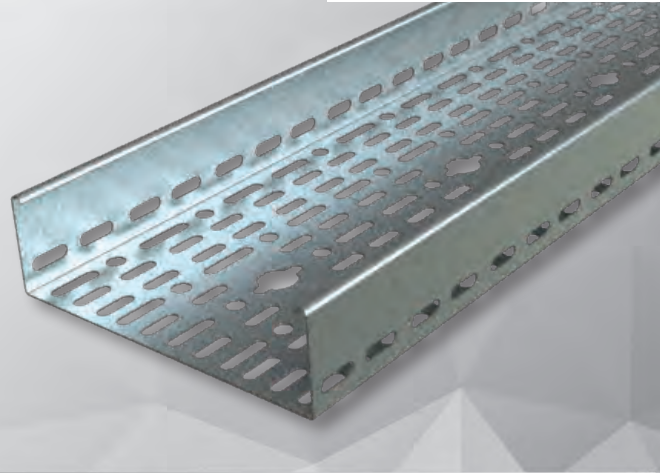

▶▶ E-LINE KM

Pre Galvanised Cable Ladder Systems

Genel Introduction

- Heavy duty type
- 40/50/60/75/100/125/150mm heights
- 100/200/300/400/500/600 widths (700-800-900-1000 special widths on request)
- 3000mm length (6000mm special length on request)
- TS EN 10346, TS EN 10143 standart pre-galvanized production
- Products can be used along the side walls in horizontal suspended application. Thereby provides a significant cost advantage.
- 300mm equally spaced traverse structure
- More cable space than traditional ladders with special traverse height
- Fire resistance certificates (E30-E60-E90)



▶▶ E-LINE CTK

Hot Dip Snap-on Covered Cable Tray Systems

Genel Introduction

- Heavy duty type
- 60 / 75 / 100mm heights
- Thickness: 1.5mm for 100/150/200/250/300mm 2mm for 400/500/600mm
- 3000mm length (6000mm special length on request)
- Plug cover structure
- TS EN ISO 1461 standard hot-dip and after special EAE protective coating over hot dip
- Possibility to connect the various accessories that 20,5 diametres hole in the middle of the tray (Allows fast mounting for devices such as lighting panel, fire detector etc.)
- Wide range of accessories
- Fire resistance certificates (E30-E60-E90)
- Galvanized steel painted finish available on request (epoxy, epoxy polyester, polyester)



TUNNEL AND RAIL SYSTEM SOLUTIONS

EAE Cable Tray Systems



▶▶ E-LINE TLS

Wire Mesh Cable Tray System

Genel Introduction

- 35-55-85-100mm heights
- 4-5mm thicknesses of horizontal and vertical wires
- Product structure is formed by compounding of wires from 100mm in the vertical direction, 50mm in the horizontal direction.
- It is produced as electro-galvanized, stainless steel, and hot-dip galvanized
- Possibility of ready to turn components, external cutting-combining methods and modules
- 3000mm length



▶▶ E-LINE KCA-CTN GRP

Glass Reinforced Polyester

Genel Introduction

- High corrosion resistance
- UV resistance
- Non-flammable
- Fire retardant
- No toxic fumes
- Long-life span
- No need to grounding
- Easy to repair
- Lightweight and easy to installation

For Ladders (KCA GRP);

- Overall heights shall be 100mm, and 150mm (loading depths, shall be 75mm, and 125mm, respectively)
- Overall widths shall be 150mm, 200mm, 300mm, 400mm, 450mm, 500mm, 600mm, 750mm and 900mm
- Overall thickness will be 5mm for H100mm height and 6mm for H150mm height
- Rung spacing 300mm as standard

For Trays (CTN GRP);

- Overall heights shall be 50mm, 80mm, and 100mm
- Overall widths shall be 150mm, 200mm, 250mm, 300mm, 400mm, 450mm, 500mm and 600mm
- Thickness shall be 3 mm for 50-300mm widths and 4,5mm for 400-600mm widths

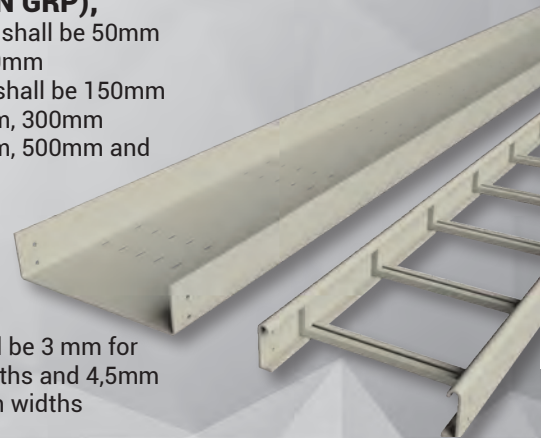

▶▶ E-LINE KCA OG

KCA OG Heavy Duty Cable Ladder System

Genel Introduction

- 6mt the is standard length and construction of the ladder is in accordance with 6mt suspension ranges
- NEMA VE 1 Standard compliance and certification
- Maximum cable bearing with Extra Heavy Duty Type Structure
- High quality raw material selection (Corten A - SS 316L)
- High production Capacity
- Fast track delivery period
- Flexible production against different specifications
- With the special form of the side rail, cable bearing capacity is upgraded
- Tested for hazardous conditions
- According to DIN4102-12 standard, it was tested at a temperature of 1000 °C for 90 minutes
- It has successfully passed the -70 °C degree test

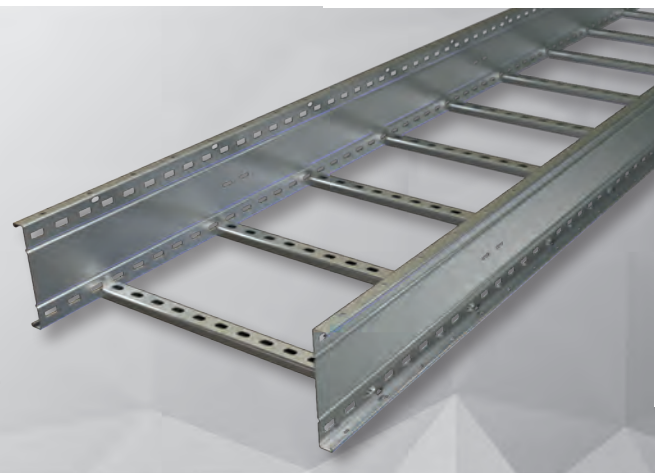

TUNNEL AND RAIL SYSTEM SOLUTIONS

EAE Cable Tray Systems



▶▶ E-LINE KCA AL

Aluminum Cable Ladder System

Genel Introduction

- 6m the is standard length and construction of the ladder is in accordance with 6mt suspension ranges
- NEMA VE 1 Standard compliance and certification
- Maximum cable bearing with Extra Heavy Duty Type Structure
- Material: Extruded Aluminum Alloy 6063-T6 (Also called marine grade Aluminum and copper-free Aluminum)
- High Production Capacity
- Fast Track delivery period
- Flexible Production against different specifications
- With the special form of the side rail, cable bearing capacity is upgraded
- Tested for hazardous conditions

Length : Standard in 3000 mm / 6000 mm

Width : 150 mm / 200 mm / 300 mm / 400 mm / 450 mm / 500 mm / 600 mm / 750 mm / 900 mm

Side Rail Height : 100 mm / 125 mm / 150 mm / 175 mm (I-BEAM DESIGN)

Loading Depth : 75 mm / 100 mm / 125 mm / 150 mm

Rung Spacing : Standard olarak 300 mm (Welded)

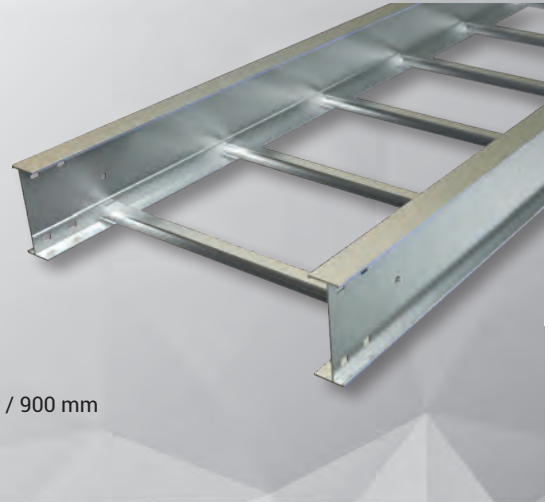

▶▶ E-LINE TKS

Pre-galvanized and Hot-dip Trunking Systems

Genel Introduction

- Heavy duty covers and locked non perforated structure
- 3 locking points every 3m
- Possibility of the quick lock cover
- H:50-75-100-150 and 200mm heights
- 50/75/100/150/200/300mm widths
- 1mm, 1,2mm and 1,5mm thickness
- Providing resistance to the passage of the grounding continuity reducer coupling (which is important for data and telephone cables)
- 3000mm lengths
- TS EN ISO 1461 standard hot-dip and TS EN 10346, TS EN 10143 standart pre-galvanized production
- Wide range of accessories

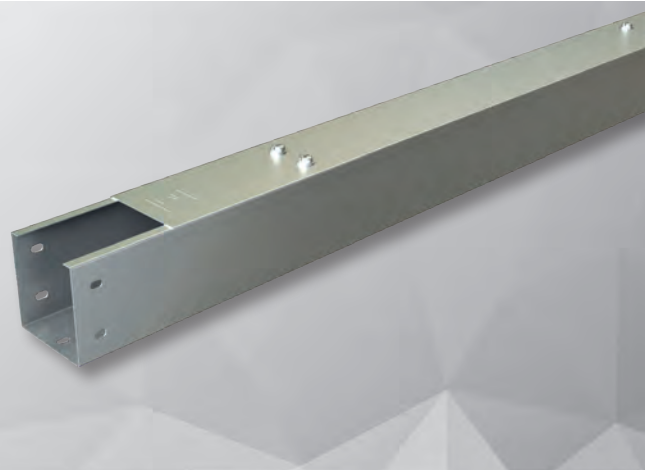

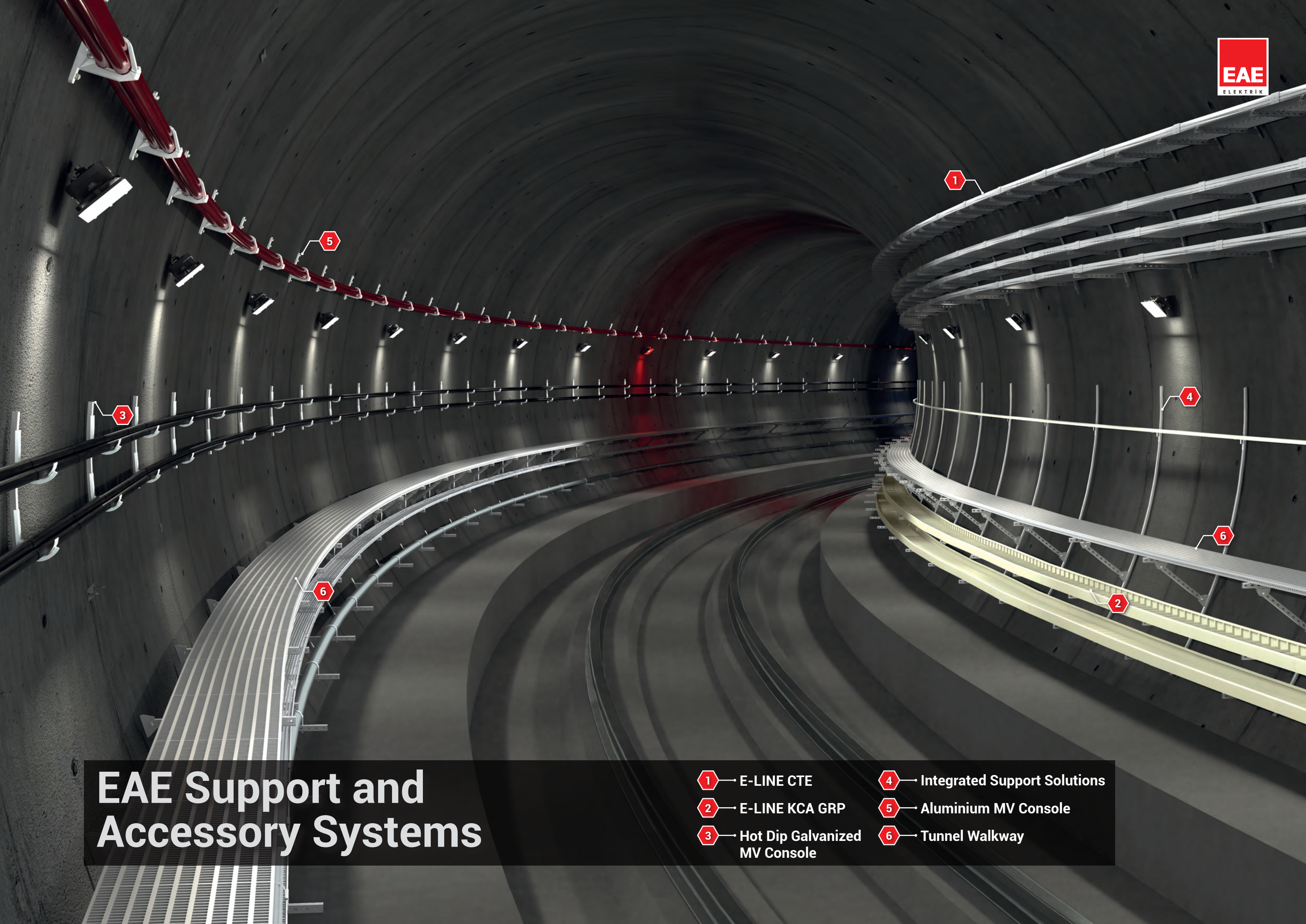

EAE Support and Accessory Systems

- 1 → E-LINE CTE
- 2 → E-LINE KCA GRP
- 3 → Hot Dip Galvanized MV Console
- 4 → Integrated Support Solutions
- 5 → Aluminium MV Console
- 6 → Tunnel Walkway

▶▶ E-LINE A-A

Aluminum Medium Voltage Console.

General Introduction

Aluminum Medium Voltage Cable Console. Thanks to its bolt-on heavy-duty structure that covers the cables from above, it ensures that the cables remain stable against the dynamic forces generated during a short circuit.



▶▶ E-LINE A-A

Hot Dip Medium Voltage Console.

General Introduction

EAE Special Medium Voltage Consoles are typically manufactured hot-dip galvanized. They can be produced with different coatings upon request. It can be manufactured welded type with specific radius according to the tunnel structural requirement. This will provide cost efficiency by allowing to faster installation and use less fixing material. EAE also offers support in load analysis and project planning through special design programs before the sale.



▶▶ E-LINE A-A

Grounding Clamp

General Introduction

Hot-dip galvanized Segment Grounding Clamp. Production is made in different sizes according to requirements. These galvanized clamps are used to ensure continuity of grounding between segments.

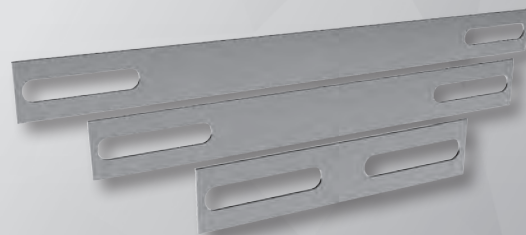

TUNNEL AND RAIL SYSTEM SOLUTIONS

EAE Support - Accessories Systems



▶▶ E-LINE BINRAK Tunnel Walkway

General Introduction

Walkways are designed for use in tunnel rail system projects during emergency situations or when a train needs to stop on the track due to a malfunction. They facilitate the evacuation of passengers and are also used for maintenance work inside the tunnel. EAE provides full system solutions by offering support in engineering calculations for the entire supporting system, project planning, and material production.

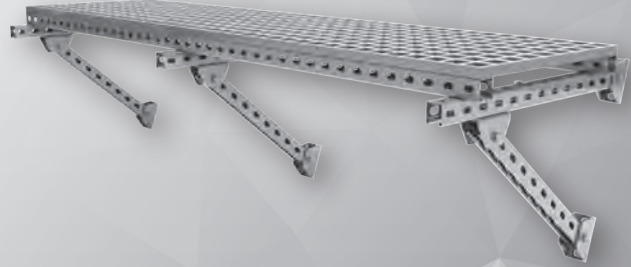

▶▶ E-LINE BINRAK Angled Tunnel Support

General Introduction

According to the angle of the tunnel structure, angled and welded special production is carried out by using EAE binrak profiles. This system requires less labor compared to the bolted system. The system is completed with only the installation of the dowels. It is more economical compared to traditional systems. The support type is created by welding radius binrak consoles, which are produced according to the tunnel diameter, onto consoles at predetermined angles. It can be supplied two, three or four levels configurations.



▶▶ E-LINE A-A Integrated Support Solutions

General Introduction

It is a modular tunnel support system that allows the installation of all equipment, such as electrical, mechanical, walkways, and handrails, on a single support. It can be produced in hot-dip galvanized, stainless steel 304, 316, or painted finishes. By mounting multiple pieces of equipment on a single support, it offers advantages in terms of installation time and cost.



TUNNEL AND RAIL SYSTEM SOLUTIONS

EAE Support - Accessories Systems



▶▶ E-LINE A-A

General Support Systems

General Introduction

- Certified seismic suspension range
- Light duty and heavy duty suspension supports
- Produced with a wall thickness of 2mm to 6mm (Only AT3 and KT types are produced with 1.5mm thickness)
- Pre-galvanized and hot-dip alternatives
- Hot-dip production in all welded supports
- Different coating alternatives for different corrosion categories.
- Customized support production
- Supports with fire resistance certificate (E30, E60, E90)

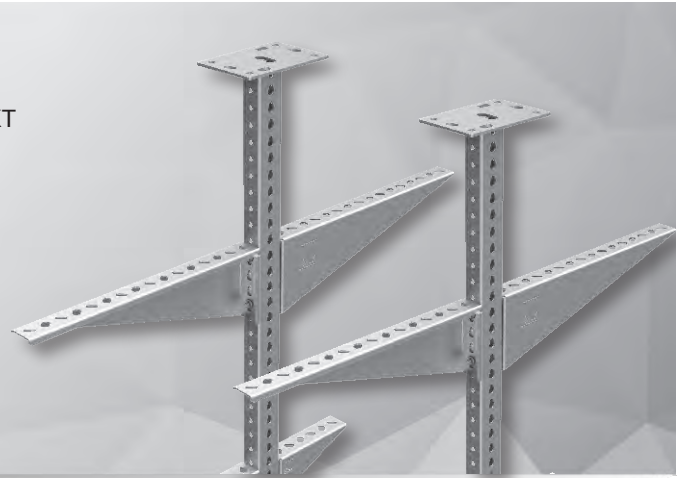

▶▶ MFIX

Electro-Mechanical Support and Suspension Systems

General Introduction

- Pre-galvanized and Hot-Dipping alternatives
- Suspension system varieties of Light, Medium and Heavy-Duty type
- Different coating alternatives for different corrosion categories
- Customized support production
- Design and calculation services are available

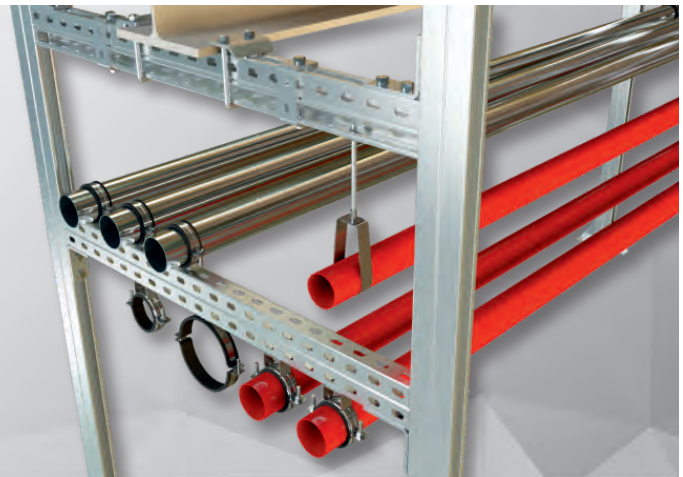

▶▶ E-LINE BINRAK

E-LINE Binrak (G Profile) Profile Series

General Introduction

- Heavy duty type
- In 41x21 mm and 41x41mm sizes as standard
- Standard $t = 1,5/2/2,5$ thicknesses are produced.
- Welding different surfaces of Binraks to each other to create stronger structures and brackets
- Large range of connection accessories and connection parts with
- Quick assembly convenience from each point on railed surface
- Possibility of using with suspension systems in mechanical, electrical and industrial areas



TUNNEL AND RAIL SYSTEM SOLUTIONS

EAE Support - Accessories Systems



▶▶ E-LINE RSP

Rectangular Smart Profile Systems

General Introduction

- Provides a 4-fold time advantage in assembly speed compared to traditional manufacturing
- Allows for creative and flexible applications due to its modular structure and accessories
- The use of intelligent bolts at connection points eliminates the need for nuts and washers
- Does not require welding and painting, offering material and labor advantages
- Provides high-capacity solutions for long span openings and heavy-load conditions
- Optional Hot-Dip Galvanizing and Stainless Steel material choices are available for corrosive environments



▶▶ E-LINE SEISMIC

Seismic Bracing Systems

Faster

Up to 50% mounting cost savings and fast installation compared to non-rigid systems.

Maximum Application

Since connection from one location is sufficient, maximum compatibility with existing installations.

Can be Installed at a Later Time

It can be installed in active facilities on the current cabling system without any dismantling.

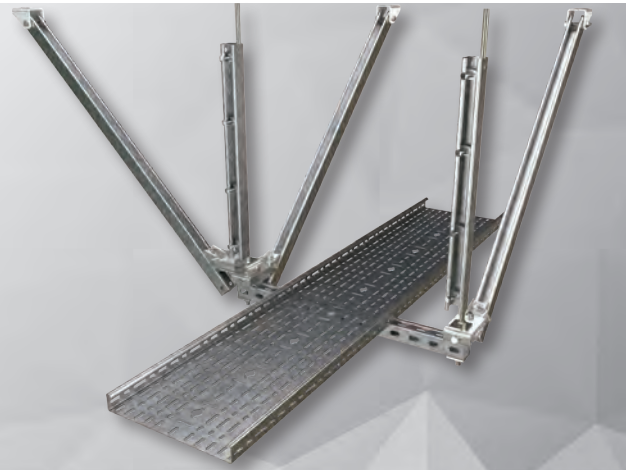

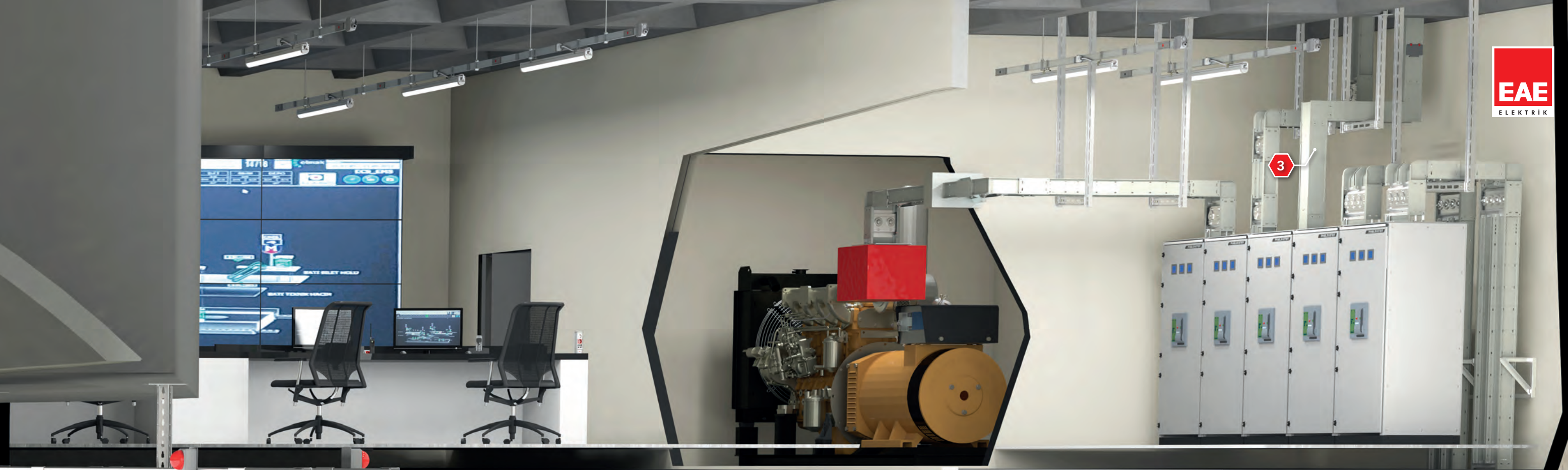

EAE Busbar Power Distribution Systems

- 1** → E-LINE KX
- 2** → E-LINE CCR
- 3** → E-LINE KO-II
- 4** → E-LINE KY-S

TUNNEL AND RAIL SYSTEM SOLUTIONS

EAE Busbar Power Distribution Systems



▶▶ E-LINE KX

Busbar Power Distribution Systems 400...6300A

General Introduction

The EAE E-Line KX Series compact busbar system is designed for use in projects requiring high power distribution, and is rated from 400A to 6300A using the latest technology

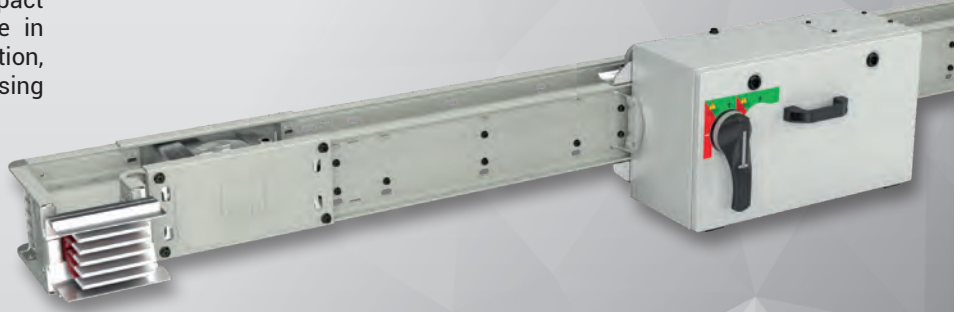

▶▶ E-LINE CCR

Busbar Power Distribution Systems 600...6300A

General Introduction

The body of the E-Line CCR busbar is formed using DURACOMP, a composite material of epoxy resin and pure silicon with Aluminium housing body which gives protection against arduous environments and high impact.

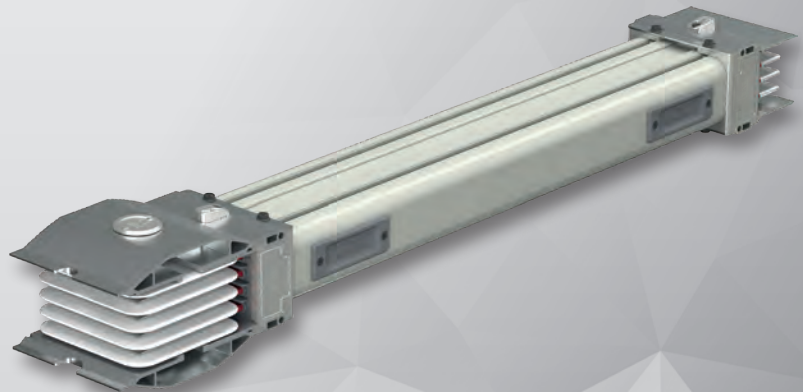

▶▶ E-LINE MV

Medium Voltage Busbar Power Distribution Systems 950A...5000A

General Introduction

The E-Line MV Series Busbar Systems, as the newest addition to the busbar product range, is offered with 12 kV and 17,5 kV variants. It offers safe and efficient power transmission. MV CR is manufactured in a single body with Cu conductors embedded in DURACOMP insulation which is a composite material of epoxy and pure silicon.



TUNNEL AND RAIL SYSTEM SOLUTIONS

EAE Busbar Power Distribution Systems



▶▶ E-LINE KO-II

Busbar Power Distribution Systems 160A...800A

General Introduction

"E-Line KO Series" medium range busbar systems provide suitable solutions for electricity transmission and distribution in medium-sized buildings or industrial facilities. They can be used in horizontal or vertical applications. Tap off box solutions comprise sheet metal boxes with circuit breakers, or plastic boxes for small currents which are compatible with Miniature Circuit Breakers.



▶▶ E-LINE KL

Busbar Power Distribution Systems 160A...1250A

General Introduction

The "E-Line KL Series" medium-range busbar systems are used in medium-sized buildings or industrial facilities, providing suitable solutions for electrical transmission and distribution in horizontal or vertical applications. They offer significant cost savings by using fuse-switch disconnectors/MCCBs (Molded Case Circuit Breakers) with metal boxes or plastic boxes compatible with MCB (Miniature Circuit Breaker) switches for smaller currents, according to specific needs.



▶▶ E-LINE KY-S

Busbar Power Distribution Systems 25-40-63A

General Introduction

KY-S Busbar System is suitable for all kinds of lighting, sockets and low power circuits with 25-40-63A current levels. Also within the scope of lighting automation, DALI and DIM circuits can be used to transmit the emergency lighting kit reference voltage.





- | | | | | | | | | | | | |
|---------|--------|-------|-------|--------|--------------|-----|---------|--|--|--|--------|
| | | | | | | | | | | | |
| England | Sweden | Italy | Egypt | Norway | Saudi Arabia | UAE | Türkiye | | | | Taiwan |

PRODUCT TYPES

BUSBAR ENERGY DISTRIBUTION SYSTEMS

CABLE TRAYS

TROLLEY BUSBAR ENERGY DISTRIBUTION SYSTEMS

INDOOR SOLUTIONS

SUPPORT SYSTEMS

Please visit our website for the updated version of our catalogues.
www.eaeelectric.com



EAE Elektrik A.S.
Head Office
Akcaburgaz Mahallesi,
3114. Sokak, No:10 34522
Esenyurt - Istanbul - TURKEY
Tel: +90 (212) 866 20 00
Fax: +90 (212) 886 24 20

EAE DL 3 Factory
Busbar
Gebze IV Istanbul Makine ve Sanayicileri
Organize Bolgesi, 6. Cadde,
No: 6 41455 Demirciler Koyu,
Dilovası - Kocaeli - TURKEY
Tel: +90 (262) 999 05 55
Fax: +90 (262) 502 05 69

EAE DL 1 Factory
Cable Tray
Gebze IV Istanbul Makine ve Sanayicileri
Organize Bolgesi, 6. Cadde,
No: 2 41455 Demirciler Koyu,
Dilovası - Kocaeli - TURKEY
Tel: +90 (262) 999 05 55
Fax: +90 (262) 502 05 70

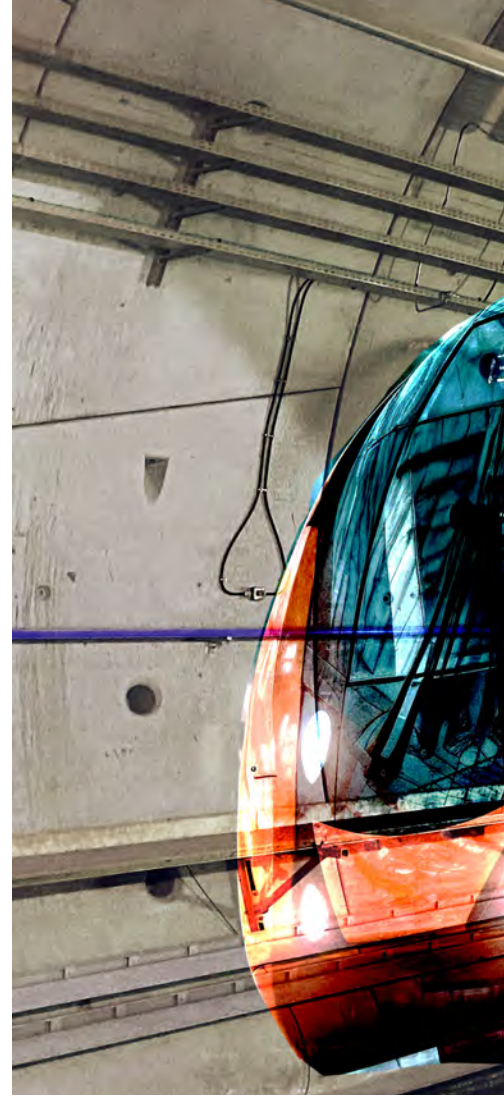

Catalogue 69-Eng. / Rev 00 / 1000 pcs. 10/12/2024
E.U.

EAE has full right to make any revisions or changes on this catalogue without any prior notice.